

# The All-New BMW 3 Series Coupe. US Media Launch



## Welcome

AUTO SPIES



# The All-New BMW 3 Series Coupe. US Media Launch



Gabriella Molteni  
Manager, Corporate Communications  
BMW of North America



# The All-New BMW 3 Series Coupe. US Media Launch



Udo Lindner  
3 Series Coupe Project Manager, Powertrain  
BMW Group



# The All-New BMW 3 Series Coupe.

Its shape ensures optimum dynamics: long, flat and stretched

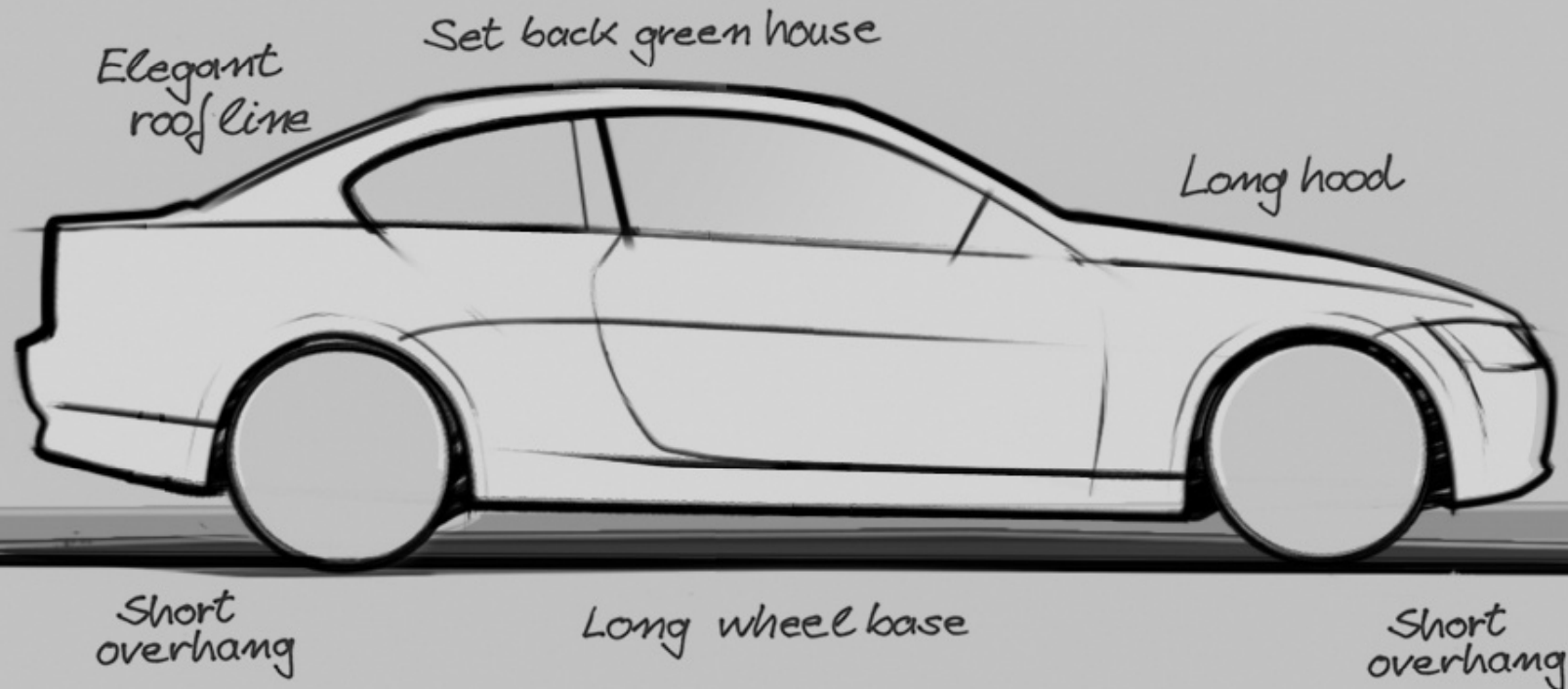

1 Classic coupe design

2 Elongated shape

3 Dynamic appearance even when parked

AUTO SPIES



# The All-New BMW 3 Series Coupe.

The design – elegance and sportiness.



1 Flowing silhouette with large, prominent wheel arches

2 Sleek and elegant roof line

3 Visual focus on BMW's rear-wheel drive

AUTO SPIES



# The All-New BMW 3 Series Coupe.

The design – elegance and sportiness.



- 1 Distinctive headlight clusters with newly-developed corona rings that also serve as daytime running lights
- 2 Unique exterior mirror design
- 3 Muscular power dome on hood, newly designed front apron

AUTO SPIES



# The All-New BMW 3 Series Coupe.

The design – elegance and sportiness.



- 1 Wider rear lamp assemblies with LED light technology
- 2 Horizontal taillight lines offer a sporty and low-slung appearance
- 3 Visual focus on widened track

AUTO SPIES





AUTO SPIES





# The All-New BMW 3 Series Coupe.

The interior – exclusive and individual.



- 1 Automatic belt presenter – a convenient comfort feature
- 2 Exclusive light package provides luxurious ambiance
- 3 Newly devised color schemes and controls with superior finish



# The All-New BMW 3 Series Coupe.

The interior – exclusive and individual.



- 1 Automatic belt presenter – a convenient comfort feature
- 2 Exclusive light package provides luxurious ambiance
- 3 Newly devised color schemes and controls with superior finish

AUTO SPIES



# The All-New BMW 3 Series Coupe.

The comfort features - innovative and geared to individual preferences.



- 1 Logic7 premium sound system with iPod connectivity
- 2 Comfort Access keyless entry
- 3 Automatic dual-zone climate control for comfortable driving

AUTO SPIES



# The All-New BMW 3 Series Coupe.

## Upmarket equipment options.



1 Optional Navigation System with iDrive control

2 Bluetooth interface

3 BMW Assist with four year subscription



# The All-New BMW 3 Series Coupe. Efficient Dynamics.

Weight



Dynamics

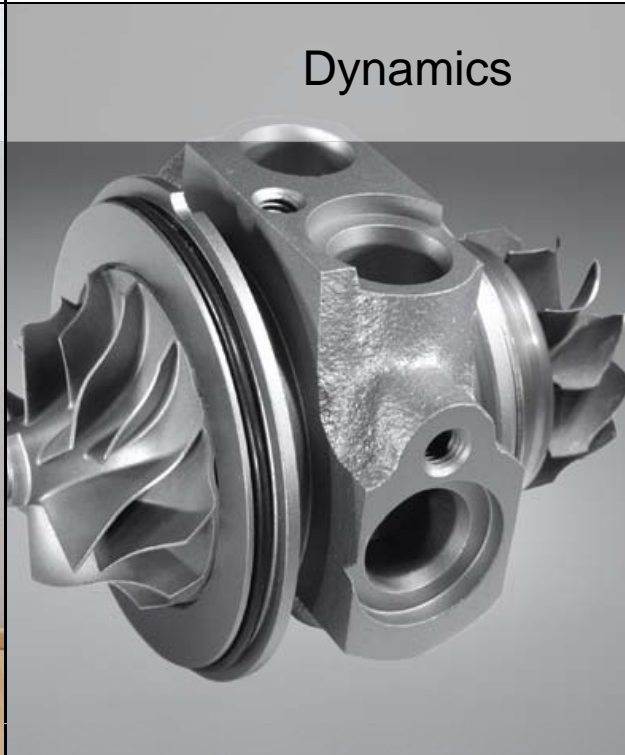

Consumption



1 Less weight through the use of innovative concepts and materials

2 Increased performance through Twin Turbo technology

3 Greater fuel efficiency with High Precision Direct Injection

AUTO SPIES



# The All-New BMW 3 Series Coupe. Innovative Material Concepts.



- 1 Magnesium steering wheel frame
- 2 Aluminum suspension components
- 3 Lightweight plastic front fenders

AUTO SPIES



# The All-New BMW 3 Series Coupe.

The world's first inline-six engine with  
Twin Turbos and High Precision Direct Injection.

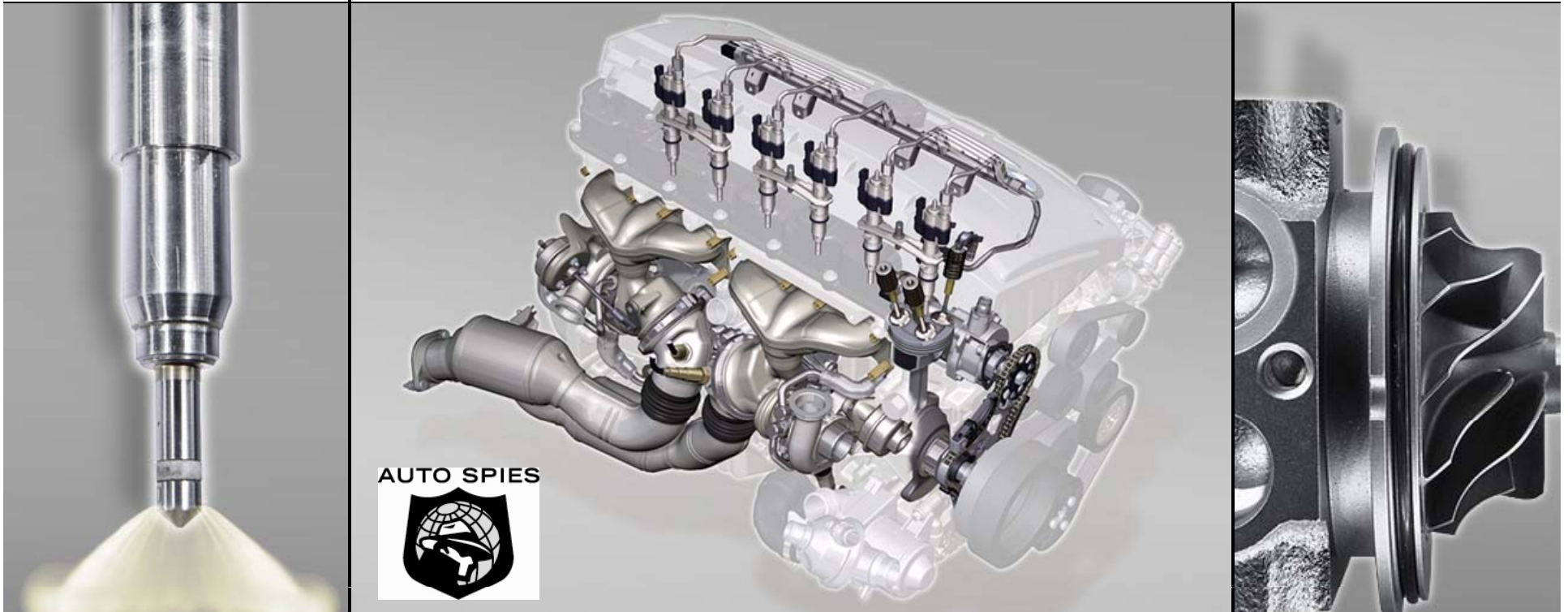

1 Increased fuel economy thanks to High Precision Direct Injection

2 Extended service life achieved with high-temperature steel traditionally employed in the aerospace industry

3 Greater response through the use of two small parallel turbochargers

# The All-New BMW 3 Series Coupe.

First gasoline direct injection system with dramatically reduced fuel consumption.

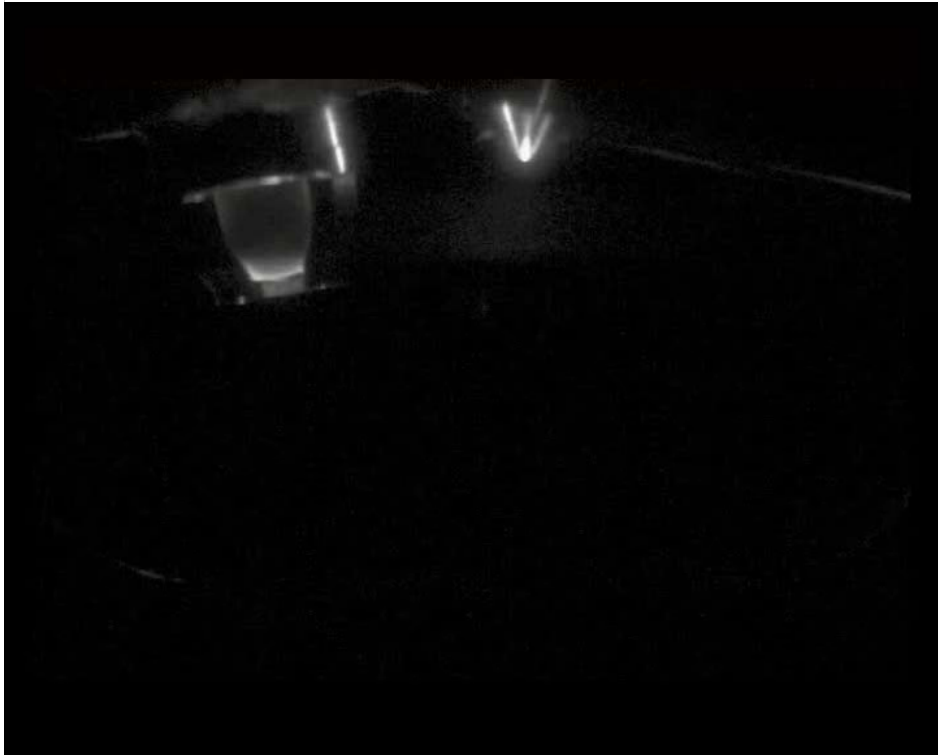

- 1 Novel outward-opening Piezo fuel injector centrally located
- 2 Fuel is more evenly distributed within the combustion chamber
- 3 More precise and economical air-fuel ratio for optimum efficiency

AUTO SPIES





# The All-New BMW 3 Series Coupe.

Combining eight-cylinder power  
with six-cylinder fuel economy.

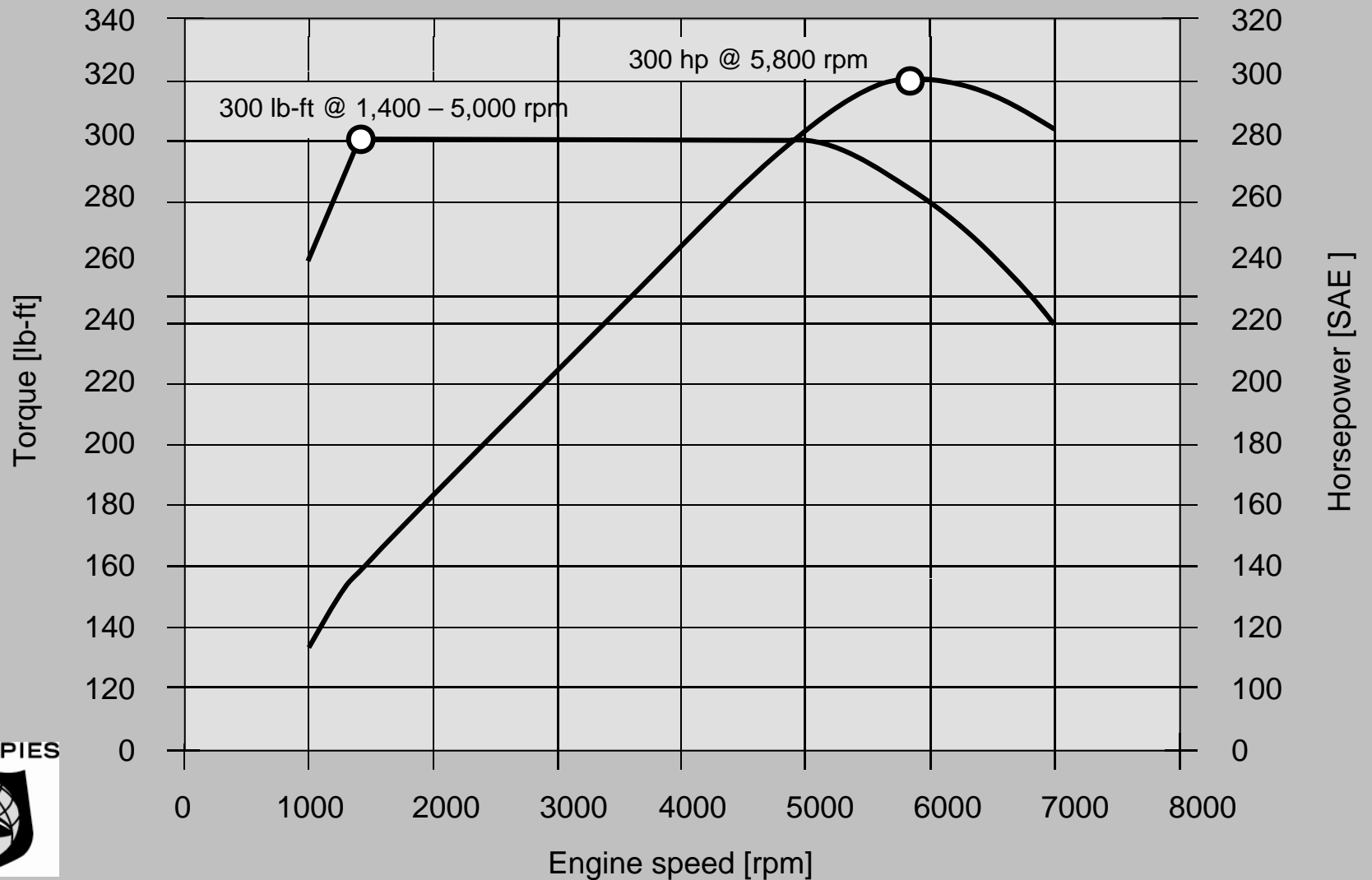

# The All-New BMW 3 Series Coupe.

Combining eight-cylinder power  
with six-cylinder fuel economy.

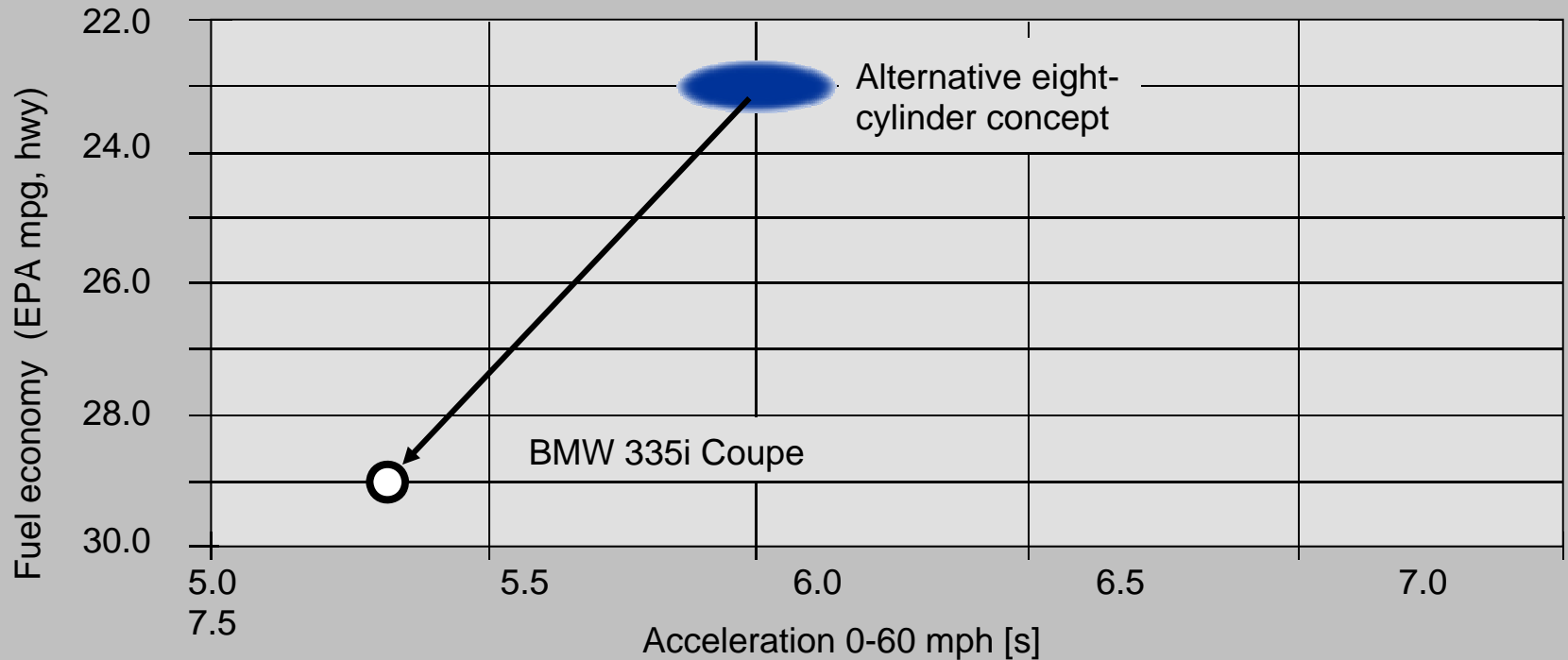

1

Output: + 15 %

Torque: + 30 %

AUTO SPIES



2

Acceleration (0-60 mph): 5.3 seconds

3

Fuel consumption (335i Coupe EPA city/hwy): 20/29 Auto, 19/28 Manual

# The All-New BMW 3 Series Coupe.

Combining eight-cylinder power with six-cylinder fuel economy.

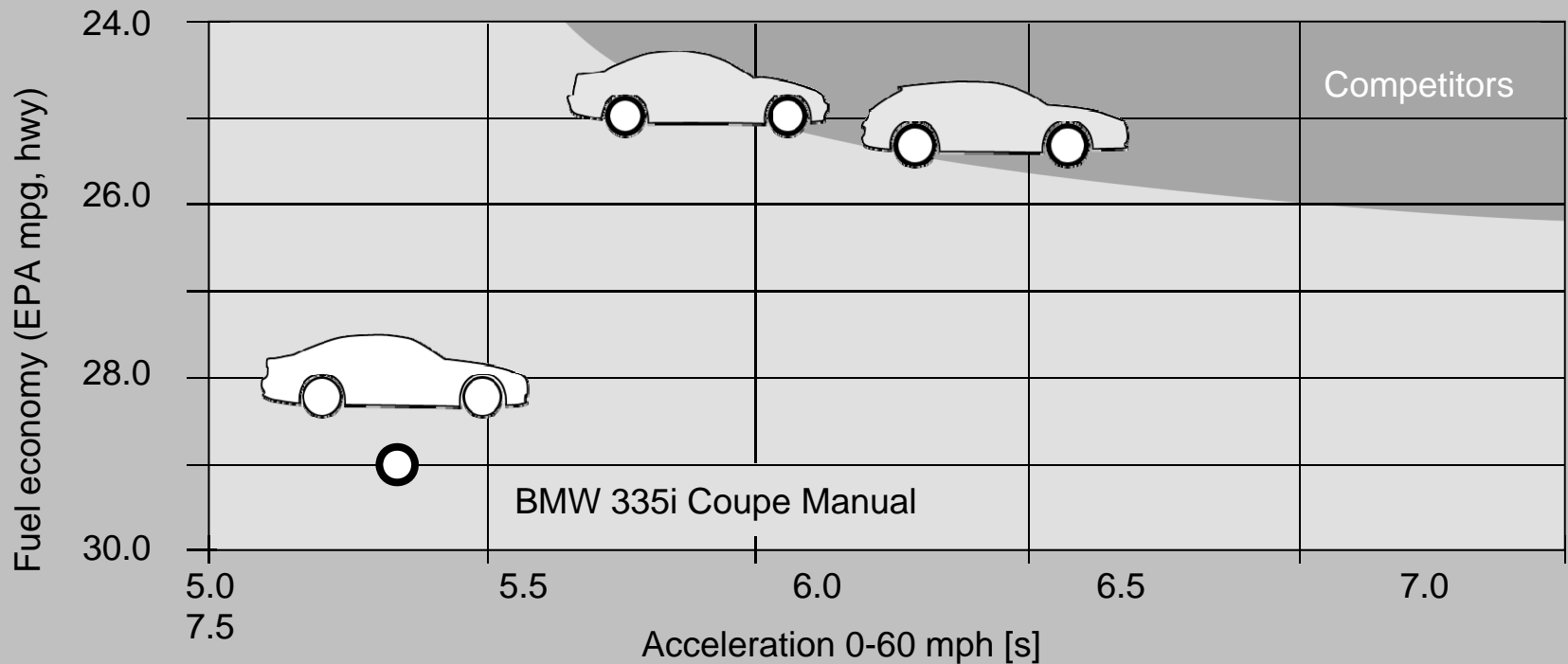

1

Power Output: + 15 %

Torque: + 30 %



2

Acceleration (0-60 mph): 5.3 seconds

3

Fuel consumption (335i Coupe EPA city/hwy): 20/29 Auto, 19/28 Manual

# The All-New BMW 3 Series Coupe.

The six-speed automatic transmission –  
faster, more dynamic, more efficient.

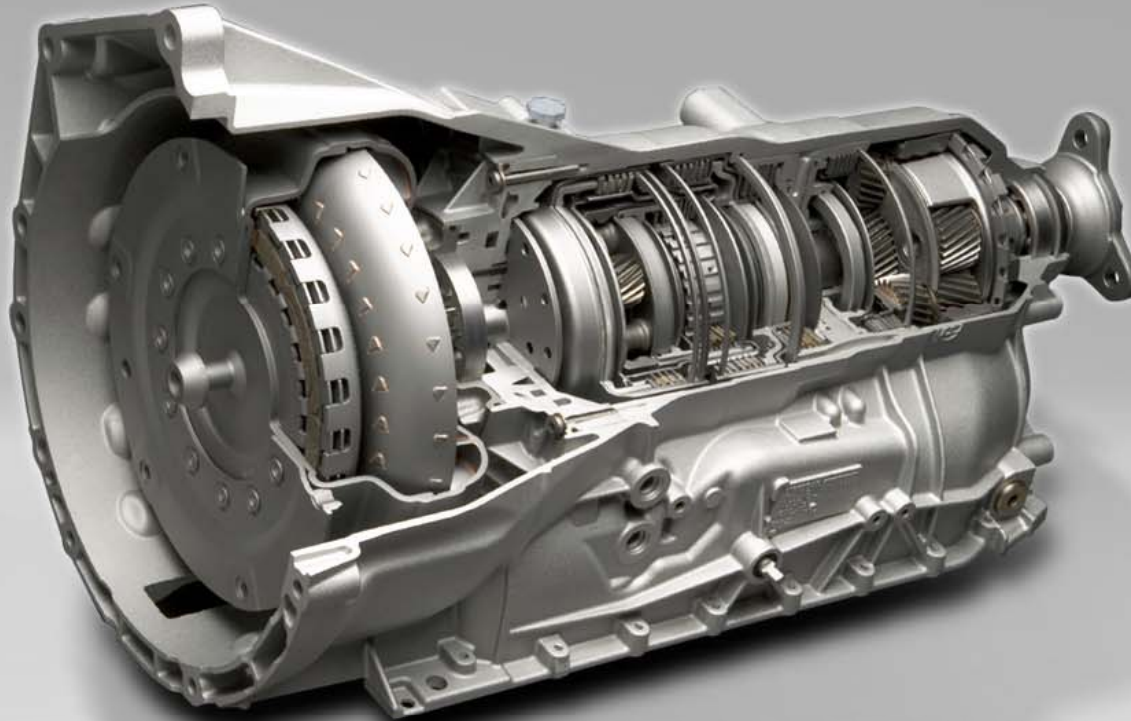

- 1 Response times 50% faster for a more active driving experience
- 2 Optimized gear selection for improved fuel efficiency
- 3 A more direct link to the engine for improved performance



# The All-New BMW 3 Series Coupe.

The six-speed automatic transmission –  
faster, more dynamic, more efficient.



- 1 Response times 50% faster for a more active driving experience
- 2 Optimized gear selection for improved fuel efficiency
- 3 A more direct link to the engine for improved performance



# The All-New BMW 3 Series Coupe.

## The engine portfolio – Efficient Dynamics.

328i Coupe  
230 hp

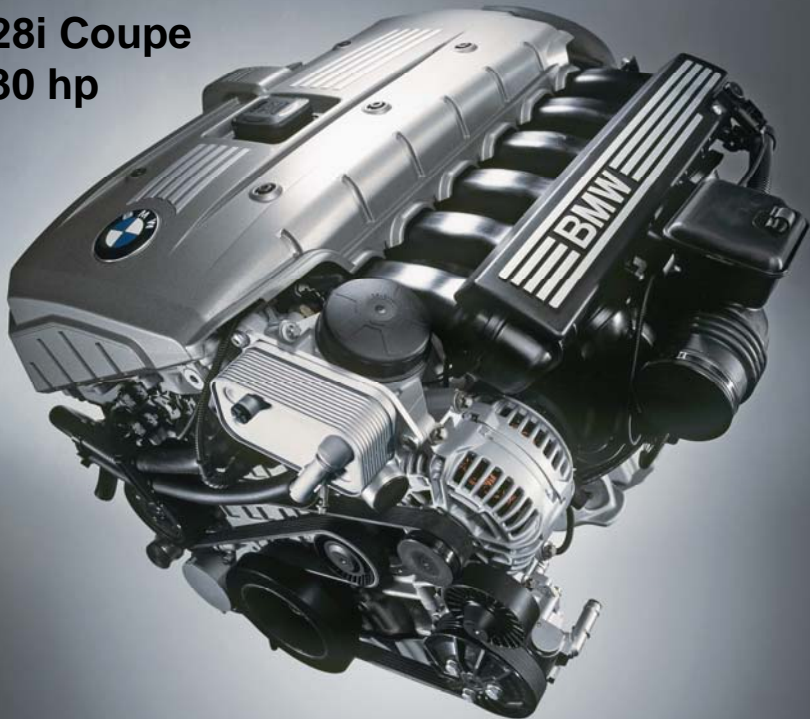

335i Coupe  
300 hp



1 3.0-liter inline-six with Valvetronic technology on the 328i Coupe

2 Twin Turbo, High Precision Direct Injection for the 335i Coupe

3 The world's most innovative inline-six engines

AUTO SPIES



# The All-New BMW 3 Series Coupe.

A world-first in a Coupe:

The intelligent xDrive all-wheel drive system.

Dynamics

Safety



1

xDrive all-wheel drive system—100 % variable distribution of power between all four wheels

2

Ultra-fast response through combined use of xDrive and DSC

3

An even sportier driving experience offered by DTC at the push of a button

AUTO SPIES



# The All-New BMW 3 Series Coupe. Active Steering.

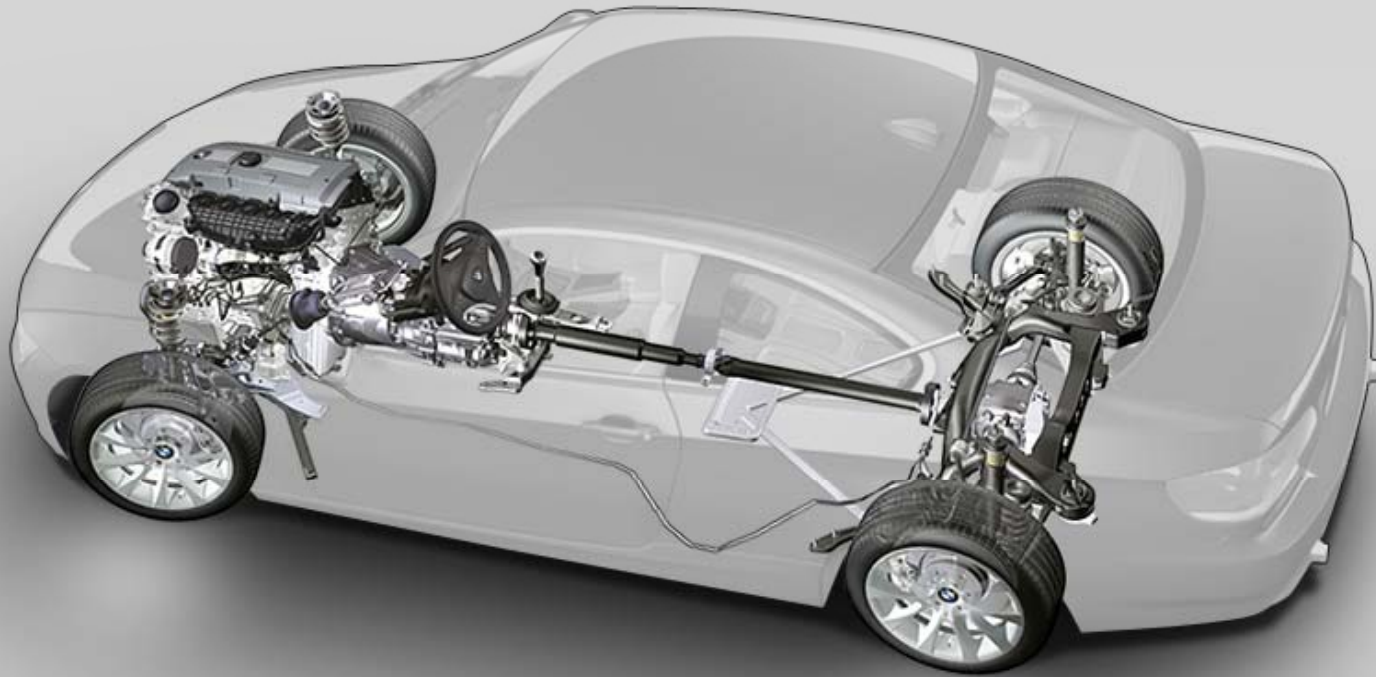

1 The ultimate in flexibility: BMW Active Steering

2 High-performance braking system featuring  
a permanent brake wear indicator

3 Safety reserves through an intelligent network of control systems

AUTO SPIES





# The All-New BMW 3 Series Coupe.

Reduced weight, increased safety.



- 1 Overall weight reduced compared to 3 Series Sedan
- 2 Body stiffness increased by 25 %
- 3 Use of innovative materials and state-of-the-art production methods for maximum safety and optimum dynamics



# The All-New BMW 3 Series Coupe.

Reduced weight, increased safety.



1 Overall weight reduced compared to 3 Series Sedan

2 Body stiffness increased by 25 %

3 Use of innovative materials and state-of-the-art production methods for maximum safety and optimum dynamics

AUTO SPIES



# The All-New BMW 3 Series Coupe.

High-tech system offering the best in active and passive safety.

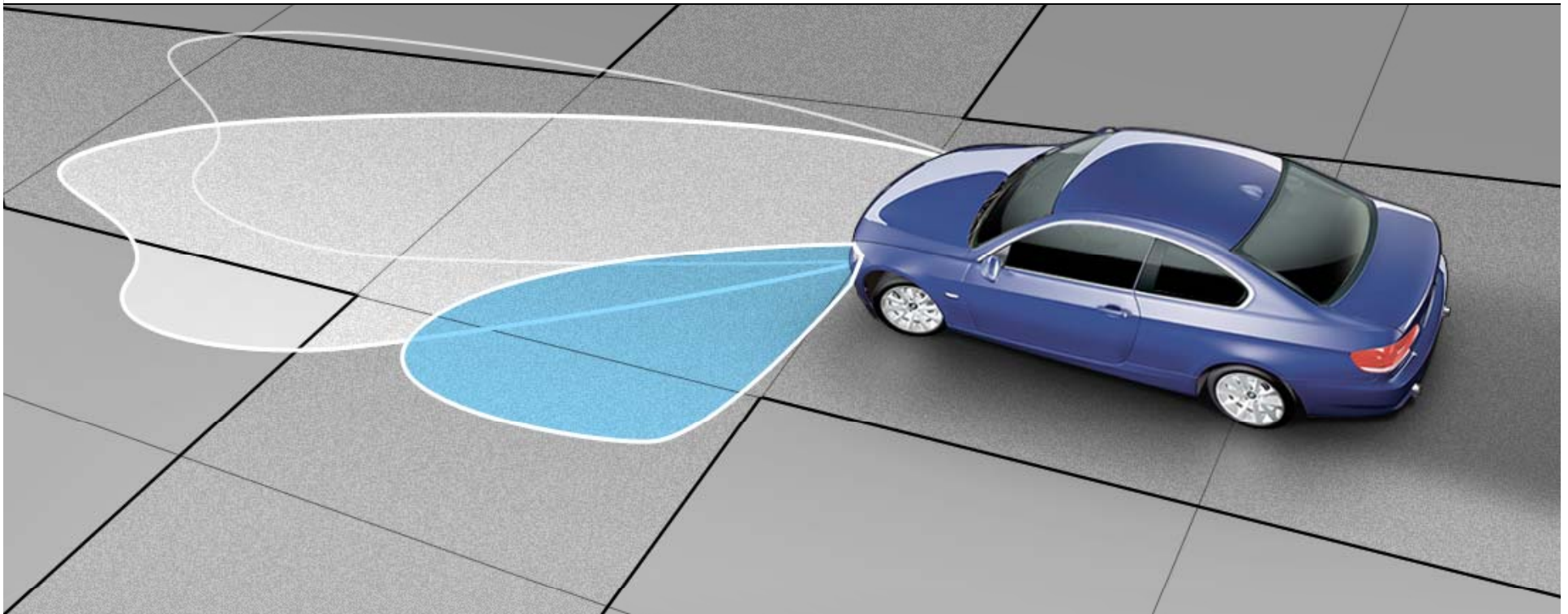

1 Xenon Adaptive headlights standard on all models

2 With the first use of Cornering Lights in the 3 Series Coupe

3 Additional safety through two-stage Adaptive Brake Lights

AUTO SPIES



# The All-New BMW 3 Series Coupe. Load capacity.



1 With a luggage compartment capacity of 11.1 cubic feet, the  
2 3 Series Coupe is yet again the leader in its segment.

3



# The All-New BMW 3 Series Coupe. Facts.

AUTO SPIES



## Design

- Classic Coupe design in a BMW specific, sporty and elegant interpretation

## Engine variants

- The world's first inline-six engine featuring Twin Turbos and High Precision Direct Injection
- The world's most innovative inline-six power unit

## Suspension

- xDrive intelligent all-wheel drive system

## Body

- Reduced weight, increased stiffness, advanced safety

## Equipment options

- High-tech systems for maximum safety and comfort



# The All-New BMW 3 Series Coupe

## US Media Launch



Ken Bracht  
3 Series Product Manager  
BMW of North America



# The BMW 3 Series History



1 BMW's 3 Series tradition goes back 40 years

2 First lineal ancestor – the 2002

3 The 3 Series was launched in the US for model year 1977. The model year 2007 3 Series Coupe represents the 5<sup>th</sup> generation of two door 3 Series.

AUTO SPIES



# The BMW 3 Series History

AUTO SPIES



- 1 A new 3 Series Sedan debuted in May 2005 with tremendous success
- 2 From May 2005 to July 2006, over 110,000 3 Series Sedans have been sold
- 3 From January to July 2006, over 55,000 3 Series Sedans have been sold – up 35% from the same period in 2005



# The BMW 3 Series

## US sales

AUTO SPIES



1 As of July 2006, almost 70,000 3 Series models sold in the US

2 The 3 Series accounts for over 44% of BMW's total US sales

3 The 2007 3 Series Coupe sales are predicted to outpace the peak sales of the previous generation

# The BMW 3 Series

## Accolades



1  
2  
3



# The All-New BMW 3 Series Coupe

## How it fits in the BMW brand



1 Performance-oriented, fun to drive

2 Attainable luxury and elegance

3 A beautiful idea. Its beauty is more than sheet metal deep.

AUTO SPIES



# The All-New BMW 3 Series Coupe

## Customer profile



1 Age group 30-49 years old

2 Pre- or post-family

3 College graduates that earn \$150,000 or more a year

AUTO SPIES



# The All-New BMW 3 Series Coupe

## Customer profile



1 Most important purchase reason is “fun to drive” factor

2 Motivated by fun, confidence, control, and freedom

3 Enjoy motorsports and racing

AUTO SPIES



# The All-New BMW 3 Series Coupe

## Customer profile

AUTO SPIES



- 1 3 Series Coupe's core audience differs based on the model variant
- 2 The 335i's core audience is married males aged 45 years
- 3 The 328i's core audience is distributed evenly between male and female

# The All-New BMW 3 Series Coupe Objectives

AUTO SPIES



- 1 Strengthen BMW's position as the benchmark in the segment
- 2 Establish the 3 Series as a world-class performance coupe
- 3 Create strong differentiation between the 3 Series Coupe and Sedan

# The All-New BMW 3 Series Coupe

## 328i Strengths

AUTO SPIES



1 Greater power and torque – 230 hp and 200 lb-ft torque

2 The all-new 328i Coupe – 0-60 6.2/6.6 is 0.9/1.3 seconds quicker

3 Availability of xDrive all-wheel drive (328xi)



# The All-New BMW 3 Series Coupe 335i Strengths

AUTO SPIES

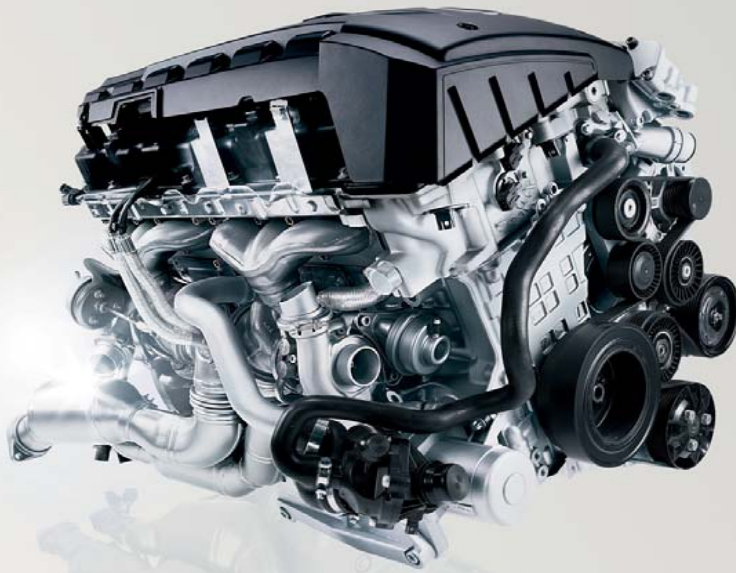

1 Impressive 300 hp and 300 lb-ft torque

2 The all-new 335i Coupe – 0-60 5.3/5.6 is 1.1/1.4 seconds quicker

3 Additional standard equipment including 8-way power front seats and Logic7

# The All-New BMW 3 Series Coupe

## New standard equipment

AUTO SPIES



1 Xenon Adaptive Headlights

2 Run-flat tires with Tire Pressure Monitor

3 Rear Head Protection System

# The All-New BMW 3 Series Coupe

## US standard equipment



1 Sport suspension calibration on 328i

2 Power glass moonroof

3 17" Wheels and Tires on 328i

AUTO SPIES



# The All-New BMW 3 Series Coupe

## US standard equipment



1 Multi-function three-spoke leather sport steering wheel

2 Ambient interior lighting

3 Dark Burl Walnut interior trim

AUTO SPIES



# The All-New BMW 3 Series Coupe Pricing



1 The 328i Coupe MSRP - \$35,995

2 The 328xi Coupe MSRP - \$37,795

3 The 335i Coupe MSRP - \$41,295

AUTO SPIES



(Includes \$695 destination)

# The All-New BMW 3 Series Coupe

## Sport Package content

AUTO SPIES



- 1 Sport seats with adjustable seat bolsters
- 2 For the 328i and 335i, large 18" wheels with performance tires and a 150 mph speed limiter
- 3 For the 328xi, 17-inch wheels with all-season tires.

# The All-New BMW 3 Series Coupe

## Premium Package content



- 1 All premium packages include lumbar support, auto-dimming interior mirror, BMW Assist with Bluetooth. The 328i also include 8-way power seats.
- 2 What's new? Compass mirror, universal garage door opener, and BMW Assist with a four-year subscription. Additionally, Leather upholstery included in the Premium Package for the 328i and 328xi.
- 3

# The All-New BMW 3 Series Coupe

## Cold Weather package

AUTO SPIES



1 328i/335i Coupe package contains: ski bag, heated front seats, retractable headlight washers

2

3 328xi Coupe package contains: ski bag and heated front seats. Retractable headlight washers are standard



# The All-New BMW 3 Series Coupe

## Package pricing

AUTO SPIES



1 Sport Package - \$1,000 for the 328i and 335i; \$400 for the 328xi

2 Premium Package - \$3,150 for 328i and 328xi; \$2,450 for the 335i

3 Cold Weather Package - \$750 for 328i and 335i; \$600 for the 328xi

# The All-New BMW 3 Series Coupe

## New stand-alone options



1 Paddle Shifters for 335i automatic with Sport Package - \$100

2 Active Cruise Control - \$2,200

3 Comfort Access - \$500



# The All-New BMW 3 Series Coupe

## New stand-alone options

AUTO SPIES



1 Active Steering - \$1,250

2 Navigation with iDrive and Voice Recognition - \$2,100

3 SIRIUS satellite radio with one year of service - \$595

# The All-New BMW 3 Series Coupe

## BMW – ultimate service



- 1 Only no-cost maintenance program that covers wear and tear items
- 2 No charge for Roadside Assistance for four years regardless of mileage
- 3 New Vehicle Limited Warranty 4 years / 50,000 miles, whichever comes first

# The All-New BMW 3 Series Coupe

## Key success factors



1 The all-new 3 Series Coupe's performance

2 Premium interior refinements

3 More appeal with the introduction of xDrive all-wheel drive

AUTO SPIES



# The All-New BMW 3 Series Coupe. US Media Launch – Thank you



Gabriella Molteni  
Manager, Corporate Communications  
BMW of North America

