

All-wheel drive at Mercedes-Benz

Contents

Page

January 4, 2007

Short version

Mercedes-Benz and the all-wheel drive: a success story

4MATIC for everyone: comfort and driving dynamics attain a new level of perfection

2

Overview

The all-wheel drive passenger cars from Mercedes-Benz

7

Long version

Model range

Four S-Class models with 4MATIC

CD

4MATIC technology in the S-Class

Latest generation of trend-setting all-wheel drive system

CD

The new-generation E-Class with 4MATIC

Ten times 4x4

CD

The Mercedes-Benz SUVs

Three all-rounders with powerful 4MATIC all-wheel drive

CD

The G-Class

Into the 28th year of production with renewed zeal

CD

Traction with tradition

Over 100 years of all-wheel drive at Mercedes-Benz

CD

Technical Data

CD

The descriptions and information in this press kit apply to the international Mercedes-Benz model range and may vary from country to country.

4MATIC for everyone: comfort and driving dynamics attain a new level of perfection

Stuttgart/Lake Placid – Mercedes-Benz has consistently been expanding its all-wheel drive line-up, setting new trends in a rapidly growing market segment. Mercedes-Benz offers no fewer than 48 models with permanent all-wheel drive in seven vehicle classes, fulfilling the wishes of drivers for effortless motoring in all weather conditions. The new flagship is the S-Class 4MATIC. Developed entirely in-house for the luxury saloon, this all-new drive system combines perfect traction, first-class ride comfort and impressive driving dynamics with good fuel economy. The new technology leader likewise carries on the tradition with its roots in the so-called “Dernburg Wagen” from 1907, one of the first Mercedes-Benz vehicles with all-wheel drive. The vehicle designed 100 years ago by Paul Daimler paved the way for all the all-wheel drive vehicles sporting the Mercedes star – the Unimog, the G-Class, the first E-Class with 4MATIC, right through to the current model line-up with the new S-Class 4MATIC as its flagship.

The top model from Mercedes-Benz with the new 4MATIC all-wheel drive is aimed at drivers whose principal requirement is for a luxury saloon able to cope with all road conditions with absolute assurance. This need is met by the S-Class 4MATIC models, whose newly developed drive system features a planetary-type centre differential. The permanent, fixed power split between the front and rear wheels in a ratio of 45 to 55 percent guarantees assured and absolutely predictable handling on all road surfaces. An integrated multiplate clutch ensures additional traction and optimum directional stability as soon as the wheels show any sign of slipping. ® With the support of the ESP®, ASR and 4ETS electronic driving safety systems, the S-Class 4MATIC offers a dynamic, comfortable and safer transport solution, even in adverse road conditions.

Trend-setting all-wheel drive system developed by Mercedes-Benz

Page 3

The 4MATIC system's compact, light and friction-optimised design offers clear advantages over other systems with regard to weight, fuel consumption, comfort and passive safety. Depending on the engine type, the all-wheel drive technology results in an unrivalled low additional weight of just 66 or 70 kilograms.

Mercedes-Benz will also be offering this trend-setting all-wheel drive technology in other passenger cars in the future. The new 4MATIC drive for the S-Class was developed independently by a team of specialists at the Mercedes Technology Center in Sindelfingen and in Stuttgart-Untertürkheim. The all-wheel drive components are produced in a coordinated production system comprising the Stuttgart-Untertürkheim, Esslingen-Hedelfingen and Esslingen-Mettingen major-component plants.

Two powerful eight-cylinder models with 4MATIC

Assured performance of the highest order is guaranteed by the S 500 4MATIC and S 450 4MATIC eight-cylinder models. In the S 500 4MATIC, the advanced 5.5-litre V8 engine with four valves per cylinder, 285 kW/388 hp and 530 Newton metres of torque offers first-class performance: the new S 500 4MATIC accelerates from 0 to 100 km/h in 5.4 seconds and is therefore as fast as the rear-wheel-drive variant. Thanks to the optimised weight and friction characteristics of the all-wheel drive system, the additional fuel consumption is agreeably low. With figures of 12.1 to 12.3 litres per 100 kilometres (NEDC combined) compared with 11.7 to 11.9 litres per 100 km for the S 500 without all-wheel drive, it is clear that the new drive system is able to offer impressive savings.

³The S 450 4MATIC is powered by a 4663-cc, eight-cylinder engine with four valves per cylinder which develops 250 kW/340 hp and 460 Newton metres of torque. Here, too, this V8 model with all-wheel drive accelerates as quickly as its rear-wheel-drive counterpart, attaining 100 km/h in 5.9 seconds. With NEDC combined fuel consumption of 11.6 to 11.8 litres per 100 kilometres, the additional fuel consumption – as in the case of the S 500 4MATIC – is only 0.4 litres.

A first for the S-Class with all-wheel drive and diesel engine

Page 4

An even more economical choice is available in the form of the new S 320 CDI 4MATIC – a model which marks a first for the S-Class by combining all-wheel drive with a diesel engine. The advanced V6 turbodiesel with common rail high-pressure injection develops 173 kW/235 hp and 540 Newton metres of torque, accelerating the saloon to 100 km/h in 7.8 seconds; the top speed is 245 km/h. With fuel consumption of between 8.7 and 8.9 litres of diesel per 100 kilometres, this model has a range of more than 1000 kilometres. Like the V8 petrol models, the S 320 CDI 4MATIC consumes just 0.4 litres more fuel than the equivalent model with a standard drive system.

On all S-Class 4MATIC models, power management is performed by the 7G-TRONIC automatic transmission with steering-column DIRECT SELECT gear selector and steering-wheel gearshift buttons. The V6 and V8 petrol-engined models are equipped as standard with the 7G-TRONIC Sport transmission, which is tuned for more direct, faster response in manual "M" driving mode.

Model range: three petrol engines and one diesel

The S 500 4MATIC, S 450 4MATIC and S 320 CDI 4MATIC are available in short and long wheelbase versions and already on sale in Mercedes-Benz sales and service outlets and authorised dealerships, to be followed by the S 350 4MATIC with a 200-kW/272-hp V6 petrol engine in mid-2007.

The most important data at a glance:

Page 5

	Cyl.	cc	kW/hp at rpm	Nm from rpm	Trans- mission	0-100 s	max Top speed (km/h)	l/100 km NEDC comb.
S 320 CDI 4MATIC	V6	2987	173/235 3600	540 1600	7G- TRONIC	7.8	245	8.7-8.9
S 450 4MATIC	V8	4663	250/340 6000	460/ 2700	7G- TRONIC	5.9	250	11.6-11.8
S 500 4MATIC	V8	5461	285/388 6000	530/ 2800	7G- TRONIC	5.4	250	12.1-12.3

Great diversity: 48 all-wheel drive models from Mercedes-Benz

The extended choice of all-wheel drive vehicles from Mercedes-Benz now comprises seven model series and impresses with its great diversity: it starts with the C-Class and E-Class, both of which are available with 4MATIC in Saloon and Estate form, and includes the new S-Class and the R-Class touring SUV, both of which are available in two body variants. Furthermore, the Stuttgart-based car manufacturer offers the GL-Class and M-Class off-rovers. The G-Class, the classic among cross-country vehicles included in the line-up since 1979, adds another dimension to the portfolio. In total, therefore, Mercedes-Benz offers no less than 48 all-wheel drive models.

This product initiative reflects the considerable emphasis which Mercedes-Benz is placing on the market for all-wheel drive passenger cars and off-rovers – a market characterised by a distinct year-on-year growth trend. A look at the S-Class segment also makes this clear: in the German and European market, the share of all-wheel drive models increased from six percent in 2002 to nine percent in 2005. Worldwide sales of the S-Class 4MATIC predecessor model, which was introduced in 2002, amounted to almost 29,000 vehicles in just under three years.

In 2005, the all-wheel drive S-Class models had a worldwide share of about 18 percent of the total sales volume of this model series. Overall, Mercedes-Benz has sold more than 1.3 million passenger cars and cross-country vehicles with permanent all-wheel drive since 1979.

Page 6

Contact:

Wolfgang Zanker, Tel. +49 711 17-75847 wolfgang.zanker@daimlerchrysler.com
Jörg Zwilling, Tel. +49 711 17-75849 joerg.zwilling@daimlerchrysler.com

Internet address:

Further information about DaimlerChrysler is available at:
www.media.daimlerchrysler.com

The all-wheel drive passenger cars from Mercedes-Benz

C-Class Saloon	C 280 4MATIC	170 kW/231 hp	4MATIC permanent all-wheel drive; 4ETS and ESP®
	C 350 4MATIC	200 kW/272 hp	
Estate	C 280 4MATIC	170 kW/231 hp	
	C 350 4MATIC	200 kW/272 hp	
E-Class Saloon	E 280 CDI 4MATIC	140 kW/190 hp	4MATIC permanent all-wheel drive; 4ETS and ESP®; optional AIRMATIC DC air suspension (standard in E 500)
	E 320 CDI 4MATIC	165 kW/224 hp	
	E 280 4MATIC	170 kW/231 hp	
	E 350 4MATIC	200 kW/272 hp	
	E 500 4MATIC	285 kW/388 hp	
Estate	E 280 CDI 4MATIC	140 kW/190 hp	
	E 320 CDI 4MATIC	165 kW/224 hp	
	E 280 4MATIC	170 kW/231 hp	
	E 350 4MATIC	200 kW/272 hp	
	E 500 4MATIC	285 kW/388 hp	
S-Class short and long wheelbase	S 320 CDI 4MATIC	173 kW/235 hp	Latest-generation 4MATIC permanent all-wheel drive; 4ETS and ESP®; AIRMATIC air suspension
	S 350 4MATIC*	200 kW/272 hp	
	S 450 4MATIC	250 kW/340 hp	
	S 500 4MATIC	285 kW/388 hp	
R-Class short and long wheelbase	R 280 CDI 4MATIC**	140 kW/190 hp	4MATIC permanent all-wheel drive; 4ETS and ESP®, optional AIRMATIC air suspension (standard in R 63 AMG)
	R 320 CDI 4MATIC	165 kW/224 hp	
	R 350 4MATIC	200 kW/272 hp	
	R 500 4MATIC	225 kW/306 hp	
	R 63 AMG	375 kW/510 hp	

* Available from mid-2007; ** Only available with short wheelbase

M-Class	ML 280 CDI 4MATIC ML 320 CDI 4MATIC ML 420 CDI 4MATIC ML 350 4MATIC ML 500 4MATIC ML 63 AMG***	140 kW/190 hp 165 kW/224 hp 225 kW/306 hp 200 kW/272 hp 225 kW/306 hp 375 kW/510 hp	4MATIC permanent all-wheel drive; 4ETS and ESP [®] , Downhill Speed Regulation, Start-Off Assist and off-road ABS. Optional Off-Road Pro engineering package with two-speed transfer case, low-range ratio, two selectable 100-percent differential locks and AIRMATIC air suspension
GL-Class	GL 320 CDI 4MATIC GL 420 CDI 4MATIC GL 450 4MATIC GL 500 4MATIC	165 kW/224 hp 225 kW/306 hp 250 kW/340 hp 285 kW/388 hp	4MATIC permanent all-wheel drive; 4ETS and ESP [®] , Downhill Speed Regulation, Start-Off Assist and off-road ABS. Standard-fit Off-Road Pro engineering package with two-speed transfer case, low-range ratio, two selectable 100-percent differential locks and AIRMATIC air suspension
G-Class Station Wagon short and long wheelbase	G 320 CDI G 500 G 55 AMG KOMPRESSOR****	165 kW/224 hp 218 kW/296 hp 368 kW/500 hp	Permanent all-wheel drive; 4ETS and ESP [®] , with low-range ratio and three selectable 100-percent differential locks
Cabriolet	G 320 CDI G 500	165 kW/224 hp 218 kW/296 hp	

*** Off-Road Pro engineering package not available, AIRMATIC as standard;

**** Available as Station Wagon with long wheelbase

Four S-Class models with 4MATIC

- **Two powerful V8 models initially, two V6 variants to follow**
- **All-wheel drive available with powerful V6 CDI engine for the first time**
- **Performance range from 173 kW/235 hp to 285 kW/388 hp**
- **Comprehensive high-tech standard equipment for all models**

The Mercedes-Benz S-Class 4MATIC range impresses with its wide variety and its ability to meet the most diverse customer requirements. Four different engines and two body variants with a long and a short wheelbase are available. At the top of the range, the S 500 4MATIC has a 5.5-litre V8 engine which develops 285 kW/388 hp and thus offers an increase in performance of more than 26 percent compared with the previous eight-cylinder powerplant. Its torque figure of 530 Newton metres is also significantly higher (by some 15 percent) than the peak value attained by its predecessor. Maximum torque is available from 2800 rpm and remains constant across a wide engine speed range up to 4800 rpm, for excellent acceleration and mid-range power:

- The new S 500 4MATIC accelerates from 0 to 100 km/h in 5.4 seconds, the same time as that taken by the S 500 with rear-wheel drive. Compared with the predecessor model, the Saloon is more than a second faster.
- In third gear, the S 500 4MATIC accelerates from 60 to 120 km/h in just 5.6 seconds.
- The top speed is 250 km/h (electronically governed).

The eight-cylinder powerplant in the S 500 4MATIC is the top drive unit in the new generation of Mercedes-Benz V-engines which was successfully introduced in mid-2004. Equipped with four valves per cylinder, infinitely adjustable intake and exhaust camshafts, a two-stage intake module and tumble flaps in the intake ducts, the V8 is among the engines with the highest power output and torque in its displacement class. Other technical highlights of this eight-cylinder engine include special shifting camshafts. These reduce the inherent pressure

fluctuations in the exhaust train and thereby considerably improve the engine's gas cycle. This makes itself felt among other things by smoother running and higher torque in the lower and medium engine speed ranges. The Mercedes V8 employs the latest lightweight construction principles, with an aluminium crankcase, low-friction cylinder liners of aluminium/silicon alloy, a forged steel crankshaft and weight-optimised connecting rods.

Fuel consumption up by just 0.4 litres compared with S 500

The fact that the combined NEDC fuel consumption of 12.1 to 12.3 litres per 100 km returned by the S 500 4MATIC represents a saving of almost one litre compared with the predecessor model – despite the new unit's higher power and torque – clearly demonstrates the efficiency of the up-to-date design and high-tech features of the new Mercedes eight-cylinder engine. Furthermore, the newly developed all-wheel drive system also has a positive impact. Optimised for weight and friction characteristics, it results in only a slight increase in fuel consumption – just 0.4 litres – compared with the two-wheel drive version of the S 500 (11.7 to 11.9 litres per 100 km).

		S 500 4MATIC
Cylinder arrangement/ valves per cylinder		V8/4
Displacement	cc	5461
Bore x stroke	mm	98.0 x 90.5
Compression ratio		10.7 : 1
Output	kW/hp at rpm	285/388 6000
Max. torque	Nm at rpm	530 2800-4800
Combined fuel consumption l/100 km		12.1-12.3
Accel.	0-100 km/h s 60-120 km/h s	5.4 5.6
Top speed	km/h*	250

*Electronically governed

Mercedes-Benz S 500 4MATIC
Leistungsdiagramm
Power Output Graph

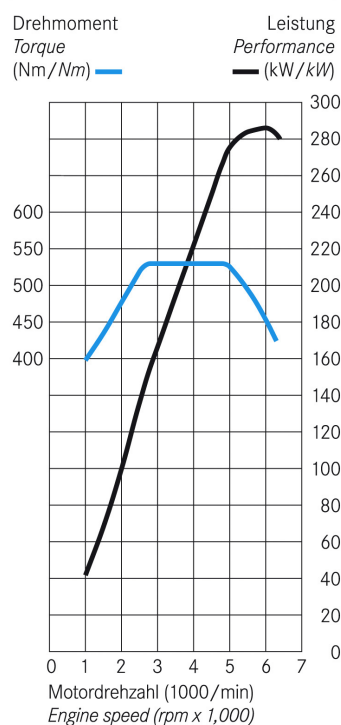

S 450 4MATIC – second V8 model with 250 kW/340 hp

The second V8 model is the new S 450 4MATIC which is now also available as a rear-wheel-drive model. Its engine technology is closely related to that of the 5.5-litre eight-cylinder unit and includes four valves per cylinder, infinitely adjustable shifting intake and exhaust camshafts, a two-stage intake module, tumble flaps in the intake ducts, an aluminium crankcase, low-friction cylinder liners, a forged steel crankshaft and weight-optimised connecting rods. With a displacement of 4663 cc, it develops a peak output of 250 kW/340 hp and its maximum torque of 460 Newton metres is available across a wide engine speed range from 2700 to 5000 rpm. The 0 to 100 km/h acceleration time of 5.9 seconds

puts the S 450 4MATIC on a par with its rear-wheel-drive counterpart. The top speed is 250 km/h (electronically governed). At 11.6 to 11.8 litres per 100 kilometres, its fuel consumption is only 0.4 litres higher than that of the "normal" S 450. This is analogous to the difference in fuel consumption between the corresponding S 500 models.

Key data at a glance:

	S 450 4MATIC	
Cylinder arrangement/ valves per cylinder	V8/4	
Displacement cc	4663	
Bore x stroke mm	92.9 x 86.0	
Compression ratio	10.7 : 1	
Output kW/hp at rpm	250/340 6000	
Max. torque Nm at rpm	460 2700-5000	
Combined fuel consumption l/100 km	11.6-11.8	
Accel. 0-100 km/h s 60-120 km/h s	5.9 6.6	
Top speed km/h*	250	

*Electronically governed

Mercedes-Benz S 450 4MATIC
Leistungsdiagramm
Power Output Graph

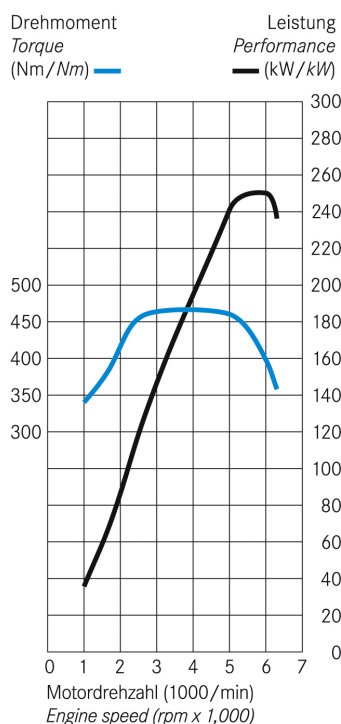

Premiere for S-Class with diesel engine and all-wheel drive

Page 13

The third S-Class all-wheel drive model – and also the most economical one – is the S 320 CDI 4MATIC. This is the first time that all-wheel drive has been combined with a turbodiesel engine in the top Mercedes-Benz model series. The advanced six-cylinder CDI unit develops 173 kW/235 hp and offers maximum torque of 540 Newton metres which is available between 1600 and 2800 rpm. These impressive figures put the direct-injection diesel among the engines with the highest power output and torque in its displacement class. As the figures suggest, the powerful six-cylinder engine offers extremely respectable performance: with a 0 to 100 km/h acceleration time of 7.8 seconds, the all-wheel drive Saloon performs to the same high standard as its two-wheel drive counterpart; the top speed is 245 km/h; thanks to the favourable NEDC combined fuel consumption figure of between 8.7 and 8.9 litres of diesel per 100 kilometres, operating ranges in excess of 1000 kilometres are possible. Compared with the rear-wheel-drive S 320 CDI, the 4MATIC model consumes only an additional 0.4 litres of diesel fuel per 100 km.

		S 320 CDI 4MATIC
Cylinder arrangement/ valves per cylinder		V6/4
Displacement	cc	2984
Bore x stroke	mm	83.0 x 92.0
Compression ratio		17.7 : 1
Output	kW/hp at rpm	173/235 3600
Max. torque	Nm at rpm	540 1600-2400
Combined fuel consumption l/100 km		8.7-8.9
Accel.	0-100 km/h s 60-120 km/h s	7.8 6.7
Top speed	km/h	245

**Mercedes-Benz S 320 CDI 4MATIC
Leistungsdiagramm
Power Output Graph**

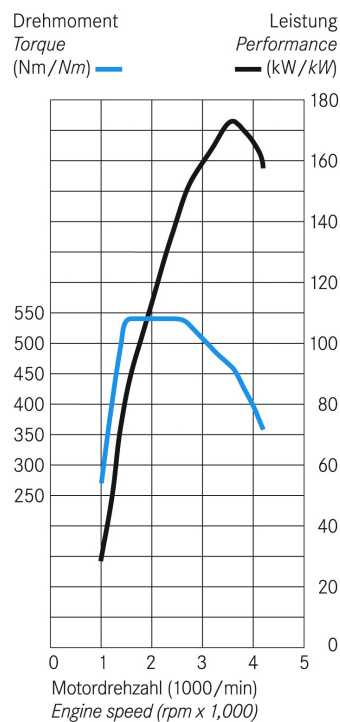

Powerful six-cylinder diesel engine with high-tech features

A glance at the technical refinements which characterise the 3.0-litre engine explains the impressive performance data. The high-tech features of this compact V6 powerplant include third-generation common rail direct injection. The combination of an injection pressure of up to 1600 bar and particularly fast-acting piezoelectric injectors ensures efficient mixture formation. Further highlights of the 320 CDI engine include electrically controlled intake port shut-off, intake air throttling, a VNT (Variable Nozzle Turbine) turbocharger with electrically adjustable guide vanes and exhaust gas recirculation with a control valve. Like all Mercedes-Benz diesel passenger cars, the S 320 CDI 4MATIC is equipped as standard with a maintenance-free particulate filter system.

7G-TRONIC automatic transmission with Sport program as standard

Page 15

Power transfer in all S-Class 4MATIC models is handled by the 7G-TRONIC automatic transmission with steering-column DIRECT SELECT gear selector and steering-wheel gearshift buttons. This combination ensures that optimum use can be made of the impressive performance and torque capabilities in every driving situation. Furthermore, the all-wheel drive models have identical gear spacing and ratios, which has a positive effect on the performance and fuel consumption figures.

An all-new development for all S-Class V6 and V8 petrol models is the 7G-TRONIC Sport transmission. The S/C/M button on the centre console can be used to activate the manual "M" driving mode, allowing the seven gears to be shifted using the two steering-wheel shift buttons – downshifts are performed by pulling briefly on the left button while the right button is used for shifting up. In "M" mode, the system's electronics reliably maintain the last gear selected, even at full throttle. It is thus possible to make optimum use of the high pulling power of the V6 and V8 engines. However, fully depressing the accelerator (kickdown mode) causes the transmission to shift down in order to deliver maximum acceleration. 7G-TRONIC Sport reduces shift times by up to 30 percent in manual mode.

PRE-SAFE® as standard, Brake Assist PLUS as an optional extra

The unique PRE-SAFE® occupant protection system also forms part of the standard equipment of the S-Class all-wheel drive models. PRE-SAFE® recognises a potential accident situation in its early stages: if the braking deceleration exceeds a certain level or there is a risk of skidding, the system tightens the front seat belts and moves the front passenger seat backrest into a more upright position as a precaution. If the vehicle is fitted with the optional multicontour seats, air is pumped into the chambers so that they envelop and support the front passenger and other vehicle occupants. The sliding roof is also closed (optional extra).

Available as an option, Brake Assist PLUS (BAS PLUS) uses radar to register vehicles ahead and warns the driver if the distance is too small or if he or she is approaching the vehicle ahead too quickly. If a collision is imminent, the system instantly calculates the ideal braking assistance, which is immediately supplied even if the driver applies the brakes too gently. This makes it possible to reduce substantially the number of rear-end collisions.® The combination of the new Brake Assist PLUS and PRE-SAFE® makes it possible to provide a higher level of occupant protection. Mercedes-Benz is the first car manufacturer in the world to offer such a comprehensive safety system as standard, which goes into action as soon as an accident risk is detected.

PRE-SAFE® Brake uses the latest radar technology

For the first time in the S-Class, Mercedes-Benz is complementing this multiple-award-winning anticipatory protection system with the newly developed PRE-SAFE® Brake. This works in combination with Brake Assist PLUS (BAS PLUS), which not only gives the driver visual and audible warnings that he or she is in imminent danger of running into the vehicle ahead, but also automatically calculates the brake pressure required to prevent an accident. This braking assistance is available as soon as the brake pedal is operated. If the driver does not react to the BAS PLUS warnings, the PRE-SAFE® Brake system triggers automatic partial braking if an acute accident risk is detected and decelerates the S-Class with about 40 percent of the maximum braking force. The automatic partial braking, which is in effect a virtual crumple zone, provides the driver with another clear signal of the need to take action. If the driver then immediately applies the brakes, the maximum braking force is available and it may be possible – depending on the situation – to avert the accident at the last moment. If an accident is unavoidable, the PRE-SAFE® Brake system reduces the impact severity and, in turn, the risk of injury to the vehicle occupants. Mercedes-Benz offers BAS PLUS and the PRE-SAFE® Brake system in conjunction with the optional DISTRONIC PLUS proximity control system.

DISTRONIC PLUS: even operates in stop-go traffic

The radar-based DISTRONIC PLUS system works in a speed range from 0 to 200 km/h and makes driving even more comfortable. In stop-go traffic, DISTRONIC PLUS keeps the new S-Class at the right distance from the vehicle ahead, automatically brakes the car to a standstill if necessary and accelerates it back to the pre-programmed speed following intervention by the driver. In this way the assistance system reduces the driver's workload and provides considerable benefits with regard to driver-fitness safety.

The Brake Assist PLUS and DISTRONIC PLUS equipment package also includes a radar-based Parking Assist system. The system provides early warning if there is danger of a collision when manoeuvring backwards and forwards.

Night view assist: infrared technology for greater safety after dark

Night view assist represents another contribution by Mercedes-Benz to reducing the risk of accidents at night. This system uses infrared light, which is invisible to the human eye and therefore does not dazzle oncoming traffic. Two infrared headlamps illuminate the road, significantly extending the driver's range of vision when on low beam. An infrared camera mounted on the inside of the windscreen picks up the reflected image of the road ahead and displays this in the instrument cluster.

Comprehensive and stylish standard equipment and appointments

Many high-tech systems which increase safety and comfort are standard in the S-Class 4MATIC models. They include the ADAPTIVE BRAKE system, second-generation PRE-SAFE[®], AIRMATIC air suspension with the Adaptive Damping System, 12-way power-adjustable front seats, the COMAND system with a DVD player, the DIRECT SELECT gearshift and automatic climate control.

Highlights of the standard equipment list include:

Page 18

- Adaptive driver and front-passenger airbags
- Adaptive brake light
- AIRMATIC with Adaptive Damping System
- 7G-TRONIC Sport automatic transmission (S 350, S 450 and S 500)
- Brake Assist
- ADAPTIVE BRAKE
- COMAND system with CD/DVD player and PCMCIA slot
- Diesel particulate filter (S 320 CDI)
- DIRECT SELECT gearshift
- ESP[®]
- Electric parking brake
- Belt force limiters on front and outer rear seats
- Belt tensioners on all seats
- Automatic climate control
- 17-inch seven-spoke light-alloy wheels
- Multifunction steering wheel
- NECK-PRO head restraints
- Speed-sensitive power steering
- PRE-SAFE[®]
- Two-stage rain sensor
- Tyre pressure loss warning system
- Front and rear outer seatbelts with automatic comfort-fit feature
- Sidebags front and rear
- Doorhold
- Front seats with lumbar supports and electric adjustment for height and fore/aft position
- Windowbags

The specification of the **S 450 4MATIC** V8 Saloon includes the following additional features:

- Tinted, sound-insulating, infrared-reflecting laminated glass all round
- 17-inch five-spoke light-alloy wheels

The **S 500 4MATIC** includes the following additional top-level features:

Page 19

- Automatically dimming rear-view mirror and driver's side exterior mirror
- Leather upholstery
- Memory package for front seats, steering column and exterior mirrors
- Metallic paintwork
- Heated front seats

The long-wheelbase version of the S-Class includes the following additional features as standard:

- Leather upholstery
- Roller blind for rear window, electrically operated
- Tilting/sliding glass sunroof, electric, with PRE-SAFE[®] function
- Front passenger seat also electrically adjustable from the rear
- Rear bench seat with electrically adjustable outer seats; outer seats and outer head restraints with PRE-SAFE[®] positioning function
- Heated front and rear seats

Latest generation of trend-setting all-wheel drive system

- **Power split between front and rear wheels in ratio of 45 to 55 percent**
- **Multiplate clutch with 50 Nm locking force offers additional traction**
- **Handling is clearly defined and always predictable**
- **Compact, lightweight design is optimised for reduced friction losses**

The Mercedes-Benz S-Class traditionally embodies the state of the art with regard to technical innovations – indeed, these have always made this top-of-the-range Mercedes the model for all passenger-car development. The same holds true for the new 4MATIC models, which are equipped with a trend-setting all-wheel drive system of the latest generation. During the concept, design and development stages of this new drive technology, the principal objectives were:

- Top traction performance on all road surfaces.
- Retention of the outstanding handling characteristics and first-class ride comfort.
- Performance and fuel consumption figures which are almost as good as those of two-wheel-drive vehicles.
- Compact and weight-optimised design.
- Attainment of the highest possible passive-safety standards.

In order to achieve these ambitious goals, the engineers and technicians at the Mercedes Technology Center (MTC) in Sindelfingen and Stuttgart-Untertürkheim decided to undertake a complete redesign of the all-wheel drive system. The permanent 4MATIC all-wheel drive system in the S-Class has a planetary-type central differential which splits the power between the front and rear wheels in a fixed ratio of 45 to 55 percent. The permanent all-wheel drive system is active all the time, operates without the need for electronically controlled clutches and does not require any reaction time. As a result, the S-Class 4MATIC offers assured, clearly defined handling which is always predictable on all road surfaces – a clear advantage over other systems. On snow and ice in particular, the adhesion of all

four wheels is maximised by a multiplate clutch whose locking force of 50 Nm ensures optimum traction. Complementing the high-precision mechanical components, the 4ETS and ASR electronic traction systems interact intelligently with the ESP[®] active safety system. The new 4MATIC all-wheel drive system is designed in such a way that other Mercedes-Benz passenger cars will be able to benefit from it in the future.

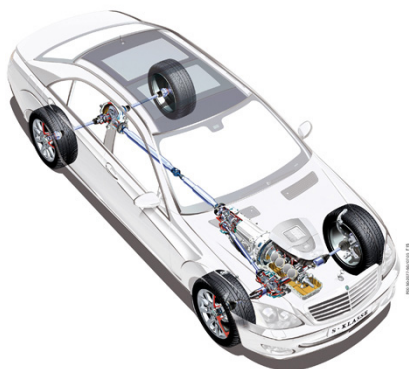

**Compact and lightweight:
The new 4MATIC all-wheel drive for the S-Class developed in-house by Mercedes-Benz**

Space-saving design with integrated transfer case

The power supply to the driven front wheels is provided via a transfer case which requires no additional installation space as it is integrated in the 7G-TRONIC automatic transmission. From here, a drive shaft supplies the power to the front axle. From the front differential, power is transmitted to the front left axle shaft by an intermediate shaft which runs through an encapsulated shaft channel in the engine oil sump.

The transfer case is notable for its compact design: by dispensing with one complete gear stage and by integrating the rear universal joint in the output gear, it is possible for the drive shaft to the front differential to run very close to the automatic transmission. Together, all these design measures allow identical floor assemblies to be used as for vehicles with rear-wheel drive. As a consequence,

customers who choose the new S-Class 4MATIC no longer have to compromise on space. Packaging the all-wheel drive technology in this way also has the advantage that the results of all the relevant crash tests are almost identical to those obtained with rear-wheel-drive vehicles.

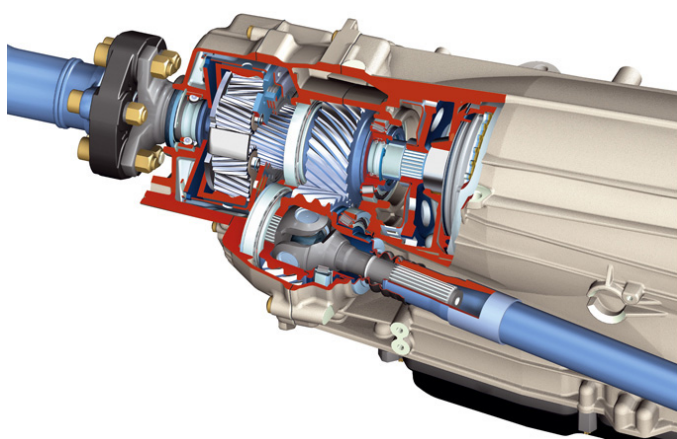

Intelligent solution:
The transfer case which supplies power to the front wheels is integrated in the 7G-TRONIC automatic transmission.

Noise and vibration comfort to typically high S-Class standards

Another benefit of this compact drive concept relates to the fact that the engine mounts are positioned on the new integral subframe and thus permit the use of extremely compact and rigid engine supports. This has a positive effect on noise and vibration comfort; on both counts, the 4MATIC models match the acknowledged high standard of the rear-wheel-drive S-Class. A no less important factor in this context is the high natural bending frequency of the entire engine-transmission unit, including the favourable integrated transfer case. The noise-optimised design of the oil supply system and all rotating components also plays an important part in this.

Additional all-wheel drive-related fuel consumption just 0.4 litres

Page 23

The inter-wheel speed difference is absorbed by means of a rear differential whose design (it is linked to the engine by a shortened propshaft) offers particular benefits with regard to fuel economy. The principle of the friction-optimised design of the rear differential has also been adopted for the newly developed front differential which has a die-cast aluminium housing: by integrating the transfer case in the 7G-TRONIC automatic transmission it has been possible to dispense entirely with one gear stage and the associated seals. Optimum lubrication efficiency is achieved by sharing the oil circuit with the automatic transmission; low-friction bearings are also used. Together, these measures allow the S-Class 4MATIC models to return additional (NEDC combined) fuel consumption of just 0.4 litres per 100 kilometres – a figure so low as to be unrivalled – compared with the rear-wheel-drive models. Furthermore, the compact and weight-optimised design results in an all-wheel drive weight premium of just 66 to 70 kilograms, depending on the engine – a clear advantage over all the competitor models. The low additional weight makes modified gear spacing and final drive ratios superfluous – another factor which has a positive effect on fuel consumption and performance figures.

Multiplate clutch offers additional traction

In addition to the permanent all-wheel drive system, an innovative multiplate clutch also helps ensure high traction in all road conditions. It is fitted to the central differential and produces a basic locking force of 50 Newton metres between the front and rear axles. If extremely low friction values – as encountered on ice, for example – are preventing one of the axles from transmitting any drive torque, the multiplate clutch helps by transferring the engine power from the axle which is turning faster to the one which is turning more slowly without any time-lag whatsoever. As a result, the wheels without traction are prevented from spinning. As well as enhancing traction, this system improves stability, too.

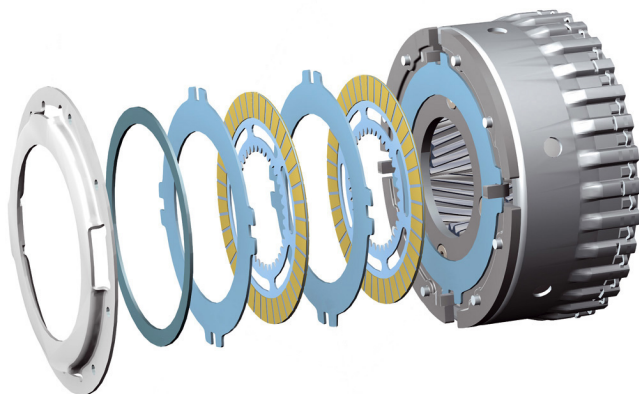

**Extra traction:
The multiplate clutch
improves take-off on
slippery surfaces.**

ESP[®], ASR and 4ETS active safety systems completely redeveloped

This highly effective technology is complemented by the ESP[®], ASR and 4ETS electronic active safety systems which have been completely redeveloped to take account of the specifics of all-wheel drive. The 4ETS traction control system uses a whole series of sensor data about the speeds of the different wheels, the steering angle as well as the vehicle's rotational motion and transverse acceleration. A micro-computer uses this data as a basis for correctly adjusting the automatic braking impulses, depending on the driving situation. This improves traction when starting out from a standstill on a slippery surface and provides greater stability during challenging driving manoeuvres.

4ETS replaces conventional mechanical differential locks and is able to brake one or more wheels at the first sign of a loss of traction, thereby instantly increasing the drive torque to the wheels with best traction. 4ETS and ASR intervene almost imperceptibly as far as the vehicle occupants are concerned and combine optimum traction with maximum driving stability and excellent handling. At low speeds, 4ETS brakes up to three wheels, which provides the same effect as three differential locks and ensures maximum traction. At higher speeds, the system reduces the automatic braking impulses to ensure driving stability.

As well as making the S-Class 4MATIC models extremely safe cars, this combination of ESP[®] and 4ETS with permanent all-wheel drive also opens up a new dimension of dynamic driving for motorists.

As with ESP[®] in model variants with rear-wheel drive, the all-wheel drive vehicles also immediately warn drivers when they approach their physical limits. In this case, a yellow warning light in the instrument cluster begins to flash. This is a clear signal warning drivers to adjust their driving behaviour to the road conditions.

New Trailer Stability Assist as additional function on ESP[®]

If the S-Class is ordered with a trailer coupling ex factory, it automatically comes with the new Trailer Stability Assist function. TSA is an additional function on the ESP[®] Electronic Stability Program which provides greater safety when driving with a trailer. TSA is able to detect the onset of those much-feared pendulum movements quickly and effectively and counteracts them swiftly. To do this, it employs the sensors from the ESP[®] system to apply the brakes in a targeted and alternating manner to individual wheels, thereby stabilising the vehicle and trailer combination.

Four-link front suspension and multi-link independent rear suspension for optimum comfort and handling

Another key element which underpins the excellent driving dynamics and high ride comfort typical of the brand is the suspension design of the S-Class. Unlike the predecessor model series, the all-wheel drive versions now feature the four-link front suspension which offers the best compromise between agility, precision and ride comfort. Equipped with the tried-and-trusted multi-link independent rear suspension, the 4MATIC Saloons are characterised by handling that is always predictable and neutral with slight understeer. At the same time, the power-assisted rack-and-pinion steering makes for precise and effortless vehicle control.

Thanks to its variable ratio (50.1 to 60.5 millimetres per steering wheel revolution), it works somewhat more indirectly in the middle of the range than at the extremes.

Comfort is considerably enhanced by the speed-sensitive feature that comes as standard: the lower the speed, the greater the power assistance. Below 200 km/h, the required steering input diminishes continuously as a function of the driving speed, so that the driver need apply only about a third of the maximum steering effort during slow parking manoeuvres. Variable centring is a special feature common to all S-Class models: the electro-hydraulic speed-sensitive servo is used to generate a centring moment that increases with the speed and gives the driver a secure and stable feeling in the straight-ahead position. In slow driving, this additional steering moment is not activated, so the benefits of the speed-sensitive steering can be fully exploited.

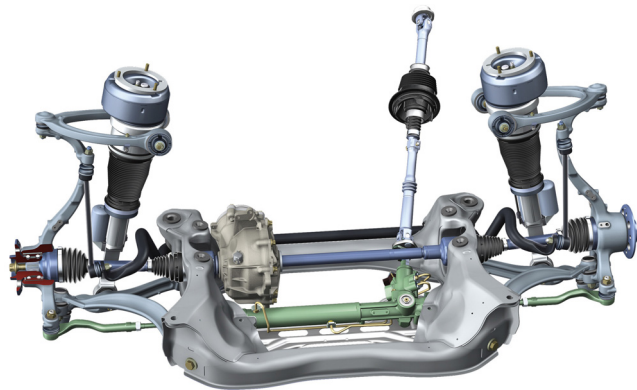

**Typical of Mercedes:
The four-link front axle
combines maximum
flexibility, precision and
ride comfort.**

Standard: AIRMATIC all-round self-levelling air suspension

Page 27

The standard-fit AIRMATIC all-round self-levelling suspension makes an important contribution to the high standard of ride comfort offered by the S-Class 4MATIC versions. When the vehicles are stationary, there is no difference between the ground clearance and ride height of the all-wheel drive and rear-wheel drive models. On rough roads, where greater ground clearance is required, the S-Class driver can simply press a button to raise ride height by 30 millimetres. AIRMATIC is combined with the Adaptive Damping System (ADS). ADS constantly regulates the shock absorber force in line with requirements, taking the road conditions, the driving style and the car's load into account. The system is able to adjust the damping force at each wheel to the requirements of the prevailing situation within just 50 milliseconds. In doing so, the skyhook algorithm regulates the damping forces in such a way that the forces exerted on the car body by the movement of the wheels are reduced. Depending on the commands received, the ADS solenoid valves on the shock absorbers can actuate any of four different damper settings:

- Stage 1: Comfortable ride with little body movement and low acceleration values, due to soft compression and rebound.
- Stage 2: Skyhook mode - soft rebound setting and hard compression.
- Stage 3: Skyhook mode - soft compression setting and hard rebound.
- Stage 4: Hard compression and rebound setting to reduce wheel load fluctuations during dynamic driving.

When experiencing few body movements, the new S-Class remains in the comfortable ADS Stage 1. If the speed of body movements exceeds a certain value, the system shifts to the skyhook algorithm and continuously switches between the second and third damping stages, with the help of fast solenoid valves, in order to offset body roll and pitching.

Another special feature is the S/C/M button in the centre console. The motorist can use this button to switch the saloon's characteristics from "comfortable" to "sporty", thereby influencing the suspension settings, ride height and transmission programming. On 4MATIC models, the shift points for all gears are optimally adapted to all-wheel drive.

- **Comfort:** In this mode, the ride height of the 4MATIC saloons is raised by ten millimetres over that of the rear-wheel drive versions, provided the speed remains below 80 km/h. When the speed exceeds 80 km/h, AIRMATIC automatically lowers the ride height by ten millimetres at both axles in order to improve stability and reduce drag. At more than 160 km/h, the body is lowered by a further ten millimetres and the compression damping is changed to "hard". When the speed drops below 40 km/h again, the system returns the body to its normal height. The automatic transmission shifts gears at lower engine speeds and allows the S-Class to move off in second gear.
- **Sport:** In this mode, the ride height is the same when on the move as for rear-wheel drive S-Class models. At speeds exceeding 100 km/h, ride height is lowered by ten millimetres at both axles and is not raised again until the speed drops below 60 km/h. The shock absorbers are set to the "hard" compression setting from 40 km/h. Gear changes take place at higher rpm.
- **Manual:** The automatic transmission can be operated manually by means of buttons on the steering wheel. The alterations to ride height and suspension settings take place in the same way as in "Sport" mode.

Ten times 4x4

- **Saloon and Estate available with 4MATIC all-wheel drive**
- **Two V6 diesel models and three petrol models with six and eight cylinders**
- **New generation even cleaner, safer, more powerful and more reliable**
- **Powerful all-wheel drive system with electronic dynamic handling control system**

Like all the other models, the 4MATIC variants also form part of the new-generation Mercedes-Benz E-Class, which boasts around 2000 new or upgraded parts. The Saloon and Estate feature new bodystyling, which is even more dynamic, poised and assured than before. And so the E-Class is once again setting the benchmark as the technology trendsetter. No other car in this market segment can match the range of safety innovations including PRE-SAFE[®], Intelligent Light System, NECK-PRO head restraints and adaptive brake lights. These extensive safety features make the E-Class the safest car in its class. The DIRECT CONTROL package with more direct steering and retuned suspension, combined with the newly developed E 500 4MATIC engine take agility and driving pleasure to new heights.

The new-generation E-Class 4MATIC is available in ten variants: the two V6 diesel models as well as the three petrol-engined models are each available in Saloon or Estate form. In the E 280 CDI 4MATIC and E 320 CDI 4MATIC, high propulsive force is provided by state-of-the-art diesel engines generating 140 kW/190 hp and 165 kW/224 hp respectively. Both CDI six-cylinder engines come with a diesel particulate filter as standard and comply with the EU4 emissions standard. The petrol-engine line-up comprises the two E 280 4MATIC and E 350 4MATIC V6 models as well as the eight-cylinder top-of-the-range E 500 4MATIC.

	Cyl.	cc	kW/hp at rpm	Nm from rpm	Trans- mission	0-100 s	max Top speed (km/h)	l/100 km NEDC comb.
E 280 CDI 4MATIC	V6	2987	140/190 4000	440 1400	5-speed automatic	8.2 (9.0)	234 (226)	7.8-8.0 (8.2-8.5)
E 320 CDI 4MATIC	V6	2987	165/224 3800	510 1600	5-speed automatic	7.4 (8.1)	244 (236)	7.9-8.1 (8.3-8.6)
E 280 4MATIC	V6	2996	170/231 6000	300 2500	5-speed automatic	7.8 (8.3)	244 (232)	9.9-10.2 (10.3-10.6)
E 350 4MATIC	V6	3498	200/272 6000	350 2400	5-speed automatic	7.1 (7.4)	250 (245)	10.4-10.7 (10.6-11.0)
E 500 4MATIC	V8	5461	285/388 6000	530 2800	5-speed automatic	5.5 (5.7)	250 (250)	12.3 (12.6)

Figures in brackets refer to Estate

4MATIC all-wheel drive system dispenses with conventional differential locks

With its exemplary driving stability and perfect traction, 4MATIC shows off its strengths especially in bad weather conditions such as wet or icy roads and snow. The system also provides further reserve traction and helps drivers to control their vehicles' behaviour when starting out from a standstill, accelerating, driving at higher speeds around bends or mastering tough terrain. This is how 4MATIC enhances the already exemplary handling properties of the E-Class and it provides the safety and superior performance associated with the Mercedes-Benz brand, even under unusually challenging driving conditions.

Drivers of models equipped with 4MATIC enjoy the advantages of these exemplary handling properties as well as the level of driving comfort typical of the Mercedes brand. This performance is guaranteed by the specially designed and tuned front axle, and by the precisely adjusted springs and shock absorbers, which in saloons and estate cars correspond to the tuning for rear-wheel drive

models. The E 500 4MATIC comes as standard with the AIRMATIC DC semi-active air suspension system, which is available as an option for all the other E-Class 4MATIC variants. All the estates come with an air suspension system with integrated level control at the rear; AIRMATIC DC is also available as an option.



**Extra comfort:
The 4MATIC all-wheel drive
system dispenses with
conventional differential
locks**

Use of traction system instead of mechanical differential locks

Still another 4MATIC feature that ensures greater comfort is the fact that it dispenses with the conventional differential locks used in other all-wheel drive passenger cars. These differential locks diminish driving comfort and require more maintenance. Instead of mechanical differential locks, the E-Class 4MATIC models feature the electronically controlled 4ETS traction system. If one or more wheels lose grip, 4ETS automatically brakes them, thereby simultaneously increasing the amount of power sent to the wheels with traction. These split-second braking pulses achieve the same effect as up to three differential locks.

All E-Class 4MATIC models are equipped with a five-speed automatic transmission as standard.

Three all-rounders with powerful 4MATIC all-wheel drive

- **ML-Class: cultivated power with effortless superiority**
- **GL-Class: first-class on and off-road**
- **R-Class: touring SUV for up to six passengers**

ML-Class, GL-Class and R-Class – Mercedes-Benz offers a customised range of versatile vehicle concepts which no other car manufacturer can match. All three SUVs feature impressive dynamic design, powerful engines, generous ride comfort and a superior drive concept, the 4MATIC all-wheel drive – turning them into the first choice for the discerning driver.

The M-Class line-up comprises three diesel variants and three petrol-engined models. The entry-level model is the ML 280 CDI 4MATIC whose 2987-cc V6 diesel engine develops 140 kW/190 hp and 440 Newton metres of torque. Next in line is the ML 320 CDI 4MATIC with the same displacement and 165 kW/224 hp and 510 Newton metres of torque. The ML 420 CDI 4MATIC is even more effortlessly superior courtesy of its V8 diesel engine delivering a maximum output of 225 kW/306 hp and torque of 700 Nm. All CDI models come as standard with a maintenance-free diesel particulate filter.

The M-Class petrol variants start with the ML 350 4MATIC whose V6 unit develops 200 kW/272 hp and 350 Newton metres of torque. At the top end of the engine range are two eight-cylinder units: the ML 500 4MATIC with 225 kW/306 hp and 460 Newton metres, and the ML 63 AMG 4MATIC whose AMG high-performance V8 engine developing 375 kW/510 hp and 630 Newton metres guarantees the kind of performance more readily associated with a sports car.

The most important data for the ML-Class at a glance:

	Cyl.	³ cc	kW/hp at rpm	Nm from rpm	Trans- mission	0-100 s	_{max} Top speed (km/h)	l/100 km NEDC comb.
ML 280 CDI 4MATIC	V6	2987	140/190 4000	440 1400	7G- TRONIC	9.8	205	9.4-9.6
ML 320 CDI 4MATIC	V6	2987	165/224 3800	510 1600	7G- TRONIC	8.6	215	9.4-9.6
ML 420 CDI 4MATIC	V8	3996	225/306 3600	700 2000	7G- TRONIC	6.8	235	11.1- 11.3
ML 350 4MATIC	V6	3498	200/272 6000	350 2400	7G- TRONIC	8.4	225	11.5- 11.7
ML 500 4MATIC	V8	4966	225/306 5600	460 2700	7G- TRONIC	6.9	240	13.4
ML 63 AMG 4MATIC	V8	6208	375/510 6800	630 5200	AMG SPEED- SHIFT 7G- TRONIC	5.0	250	16.5

The 4MATIC permanent all-wheel drive with a fixed 50 : 50 power split comes with the 4ETS traction system and additional functions such as Downhill Speed Regulation, Start-Off Assist and off-road ABS. The M-Class can be ordered with two different variants of the all-wheel drive system, allowing it to meet the diverse requirements of off-road drivers: in addition to the basic version, the Off-Road Pro engineering package is optionally available; it enables the M-Class to master even the toughest routes across rough terrain. Its primary features include a two-speed transfer case with a low-range ratio, manually or automatically selectable differential locks (100 percent) between the front and rear axle and at the rear axle, an underride guard, and a modified version of the AIRMATIC air suspension system tailored to off-road driving, which can raise the ground clearance by 110 mm to as much as 291 millimetres and the vehicle's fording depth to a maximum of 600 millimetres.

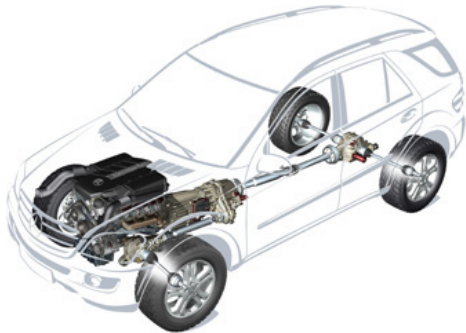

**High-tech package:
The M-Class features a
sophisticated all-wheel-
drive system**

The air suspension also significantly improves ride comfort, which is why Mercedes-Benz offers a road-going version of this technology as an option. AIRMATIC works as standard in tandem with the Adaptive Damping System (ADS), which regulates the damping to suit the individual situation. And in turn the M-Class is opening up new dimensions in dynamic handling and ride comfort. The standard specification for the ML 63 AMG 4MATIC features the AMG sports suspension based on the AIRMATIC package; the powerful top-of-the-line model also comes with a decidedly sporty set-up for the all-wheel drive: the power from the AMG V8 engine is split 40 : 60 between the front and rear wheels to deliver outstanding dynamic handling.

GL-Class: seven-seater premium off-roader

Mercedes-Benz has added a new highlight in the market segment for luxury Sports Utility Vehicles: the GL-Class. The seven-seater premium off-roader offers excellent handling both on and off-road and pampers occupants with its extremely spacious accommodation and the comfort of a luxury saloon. The GL-Class sets another milestone with the extensive PRE-SAFE® safety system, a first in this market segment.

The GL-Class meets all the requirements of a state-of-the-art, innovative SUV and even redefines them on a higher level. Yet the hallmark Mercedes off-roader genes such as superlative robustness, ruggedness and long-term durability have not been compromised. It is not without reason that the model designation echoes the legendary precursor of all Mercedes-Benz off-road vehicles – the G-Class. The evergreen off-roader is now in its 27th year of production and will continue to be marketed alongside the new GL-Class.

With its effortlessly superior presence, the GL-Class leaves one in no doubt about its aspirations to conquer this market segment. The distinctive design idiom exudes power and exclusivity. Calm body surfaces, powerful, wedge-shaped features and striking details give the impression the luxury off-roader is surging forward even when stationary. The spacious body (length 5088 mm, width 1920 mm, height 1840 mm) is beautifully proportioned, giving the exclusive all-rounder its compelling looks.

The engine line-up includes four advanced powerplants that make driving a sheer pleasure thanks to their smooth torque and power delivery. The V8 diesel engine in the GL 420 CDI delivers 225 kW/306 hp and provides the ideal conditions for superior powertrain comfort courtesy of the 700 Newton metres of torque. The tried-and-trusted V6 diesel engine in the GL 320 CDI moves effortlessly with its 165 kW/224 hp and 510 Newton metres. Both common-rail diesel units feature maintenance-free particulate filters as standard. In addition to the 285-kW/388-hp 5.5-litre V8 engine in the GL 500, a second eight-cylinder model is available – the GL 450 with a maximum output of 250 kW/340 hp.

The most important data for the GL-Class at a glance:

	Cyl.	cc	kW/hp at rpm	Nm from rpm	Trans- mission	0-100 s	Top speed km/h	l/100 km NEDC combined
GL 320 CDI 4MATIC	V6	2987	165/224 3800	510 1600	7G- TRONIC	9.5	210	9.8-10.0
GL 420 CDI 4MATIC	V8	3996	225/306 3600	700 2000	7G- TRONIC	7.6	230	11.6-11.8
GL 450 4MATIC	V8	4663	250/340 6000	460 2700	7G- TRONIC	7.2	235	13.3-13.5
GL 500 4MATIC	V8	5461	285/388 6000	530 2800	7G- TRONIC	6.5	240	13.9-14.1

Outstanding handling on and off-road

4MATIC – the permanent all-wheel drive from Mercedes-Benz – provides the GL-Class with superior handling whatever the conditions. Together with the standard-fit AIRMATIC air suspension, the precise speed-sensitive power steering and the Adaptive Damping System (ADS) also fitted as standard, the imposing GL-Class (wheelbase 3075 mm) handles impressively.



Complete solution:
The GL-Class comes
as standard with
AIRMATIC air
suspension and the
Off-Road Pro
engineering package

While the GL-Class cuts a fine figure on the road, its performance off the road is equally impressive. The modified AIRMATIC system permits a ground clearance of 307 mm in the highest off-road mode, in which case the fording depth is 600 mm. Should the ground clearance on occasion prove insufficient, a steel underride guard protects the important chassis and powertrain components.

The standard-fit Off-Road Pro engineering package extends the range of options for negotiating normally impassable terrain considerably. Thanks to the transfer case reduction gearing (2.93 : 1) and multiple-disc locks with up to 100% locking at the reinforced rear axle and in the centre differential, almost all off-road terrain becomes passable. The traction-control measures are backed up by the 4ETS electronic traction control system. In addition to 4ETS, further electronic dynamic handling control systems help to make the GL-Class driver's job easier when negotiating difficult terrain, such as the off-road ABS system, Downhill Speed Regulation (DSR) and Start-Off assist.

R-Class: two wheelbases and five engine variants

Mercedes-Benz has realised an automobile concept with the R-Class, which combines exemplary ride comfort with superb adaptability, large load capacity (up to 2385 litres), typical Mercedes safety and sophisticated design. The 4+2-seater meets the wishes of today's motorists for a car for the family, recreation, touring and business – a car for every occasion in fact. The model line-up also offers additional versatility with the touring SUV available in two body variants, offering a choice of wheelbase (2980 or 3215 millimetres) and length (4922 or 5157 millimetres).

The engine line-up corresponds largely to that of the M-Class: the two diesel R 280 CDI 4MATIC and R 320 CDI 4MATIC variants developing 140 kW/190 hp and 165 kW/224 hp respectively provide superb touring combined with outstanding economy and come with a maintenance-free particulate filter as standard. Next in line are the R 350 4MATIC and R 500 4MATIC developing 200 kW/272 hp and 225 kW/306 hp. The R 63 AMG 4MATIC is available as the exclusive high-end model; its AMG 6.3-litre V8 engine generates 375 kW/510 hp and maximum torque of 630 Newton metres.

	Cyl.	cc	kW/hp at rpm	Nm from rpm	Trans- mission	0-100 s	Top speed km/h	l/100 km NEDC combined
R 280 CDI* 4MATIC	V6	2987	140/190 4000	440 1400	7G- TRONIC	9.9	210	9.3-9.5
R 320 CDI 4MATIC	V6	2987	165/224 3800	510 1600	7G- TRONIC	8.7 (8.8)	222	9.3-9.5
R 350 4MATIC	V6	3498	200/272 6000	350 2400	7G- TRONIC	8.3 (8.4)	230	11.4-11.6 (11.5-11.7)
R 500 4MATIC	V8	4966	225/306 5600	460 2700	7G- TRONIC	6.9 (7.0)	245	13.3-13.9
R 63 AMG 4MATIC	V8	6208	375/510 6800	630 5200	AMG SPEED- SHIFT 7G- TRONIC	5.0 (5.1)	250	16.3

* Only available with short wheelbase; figures in brackets refer to models with long wheelbase

The 4MATIC permanent all-wheel drive splits the engine power 50 : 50 between the front and rear wheels. The electronically controlled 4ETS and ESP[®] dynamic handling control systems offer peerless driving safety and keep the R-Class safely on course, even in very bad road conditions. These systems all make up part of the vehicle's standard specification, as does the air suspension at the rear axle. The optional all-round AIRMATIC air suspension with the Adaptive Damping System (ADS) lowers the body by 20 millimetres at high speed to reduce wind resistance.

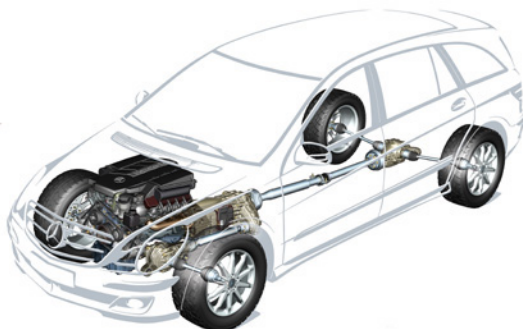

No compromising on safety: All R-Class models feature 4MATIC permanent all-wheel drive

The AMG sports suspension based on the AIRMATIC package is part of the standard specification for the R 63 AMG 4MATIC; the powerful top-of-the-line model also comes with a decidedly sporty permanent all-wheel drive: the power from the AMG V8 engine is split 40 : 60 between the front and rear wheels to deliver outstanding dynamic handling.

New Trailer Stability Assist as additional function on ESP®

Anyone ordering the M-Class, GL-Class or R-Class with a trailer coupling ex factory will also benefit from the new Trailer Stability Assist function. TSA is an additional function on the ESP® Electronic Stability Program which provides greater safety when driving with a trailer. TSA is able to detect the onset of those much-feared pendulum movements quickly and effectively and counteracts them swiftly. To do this, it employs the sensors from the ESP® system to apply the brakes in a targeted and alternating manner to individual wheels, thereby stabilising the vehicle and trailer combination.

Into the 28th year of production with renewed zeal

- **G 320 CDI: advanced V6 diesel engine developing 165 kW/224 hp**
- **All-wheel drive expertise: powerful drive and safety systems**
- **Versatility: three body variants, one exclusive AMG top-of-the-line model**

Never before has the Mercedes-Benz G-Class been so modern, innovative and comfortable. The latest incarnation of the classic off-road vehicle, which has been in production for 27 years, comes with an advanced V6 diesel engine. The 2987-cc light-alloy powerplant delivers 165 kW/224 hp and a maximum torque of 540 Newton metres, and is fitted as standard with a maintenance-free particulate filter. The G-Class line-up also includes two eight-cylinder models: the G 500 developing 218 kW/296 hp and the G 55 AMG whose AMG V8 supercharged engine boasts an output of 368 kW/500 hp and 700 Newton metres of torque.

The most important data for the G-Class at a glance:

	Cyl.	cc	kW/hp at rpm	Nm from rpm	Trans- mission	0-100 s	Top speed km/h	l/100 km NEDC combined
G 320 CDI	V6	2987	165/224 3800	540 1600	7G-TRONIC	9.1	177	11.0
G 500	V8	4966	228/296 5500	456 2800	7G-TRONIC	7.5	190	15.5
G 55 AMG	V8	5439	368/500 6100	700 2750	5-speed automatic trans- mission	5.5	210	15.9

All figures refer to long Station Wagon

And in terms of drive system the Mercedes-Benz evergreen off-roader is still rated one of the best vehicles in its class. The standard-fit, electronically controlled 4ETS traction system improves adhesion when moving off and accelerating on slippery, wet or icy surfaces. The Electronic Stability Program ESP[®] and the automatic Brake Assist system are also standard across the current G-Class range, along with the permanent all-wheel drive. In difficult off-roading conditions, three selectable differential locks with a locking factor of 100 percent and a low-range transfer case ratio can be engaged at the touch of a button.

The G 320 CDI and G 500 models are offered in all three body variants: the two Station Wagon versions with short or long wheelbase as well as the lavish Cabriolet with electro-hydraulic soft-top are available. The G 55 AMG top-of-the-line model is only available as a five-door Station Wagon.

Over 100 years of all-wheel drive at Mercedes-Benz

- **In 1903 Paul Daimler laid the foundations for the company's all-wheel drive system**
- **The "Dernburg Wagen" made its debut in 1907, featuring revolutionary all-wheel steering**
- **Unimog, G-Class and the first E-Class 4MATIC as further milestones**

The Mercedes-Benz all-wheel drive story started in 1903. Ever since, the company has adhered to a clear policy: if you want to tackle difficult terrain safely and effectively, the all-wheel drive is the best technology. Over the decades it has been used successfully in very different Mercedes-Benz vehicles, in passenger cars and commercial vehicles. Some models, the G-Class or the Unimog for instance, bask in a legendary worldwide reputation. Yet even on normal roads, the all-wheel drive delivers superb performance, as the Mercedes-Benz saloons and SUVs with 4MATIC demonstrate.

As early as 1903, Paul Daimler laid the foundations for designing vehicles with all-wheel drive. The son of company founder Gottlieb Daimler was the then Head of Engineering at the Austrian Daimler-Motoren-Gesellschaft in Neustadt, Vienna. In 1904/05 a military towing vehicle was built with all-wheel drive. Over the following years, several towing vehicles and armour-plated cars were developed with all-wheel drive. Yet it wasn't until World War I that the car finally supplanted the horse-drawn carriage within the military. Later all-wheel drive vehicles were increasingly used on building sites or for snowploughing. Benz & Cie. was keen to cash in on this development and so all-wheel drive commercial vehicles were also developed in Gaggenau.

All-wheel drive and all-wheel steering: the “Dernburg Wagen”

Page 43

In 1907 the German Imperial Colonial Office ordered a vehicle from the Daimler-Motoren-Gesellschaft (DMG) for a very special mission: it was to be used in the then German Southwest Africa colony, the current Namibia. Excellent off-road mobility was part of the specification. Paul Daimler designed an all-wheel drive vehicle, only one of which would be built in the DMG Berlin-Marienfelde plant. The car was named after Bernhard Dernburg (1865 to 1937), State Secretary of the German Imperial Colonial Office, who used the vehicle in German Southwest Africa on official business in 1908. The trail of this unique vehicle goes cold in the post-colonial era – its whereabouts now a mystery.

The vehicle featured a touring car body with six seats. It was an imposing vehicle: measuring around 4.90 metres long, height including roof more than 2.70 metres and a track of 1.42 metres, its kerb weight was around 3.6 tonnes. The vehicle had permanent all-wheel drive and even all-wheel steering for better manoeuvrability. All of the power-transmission components were shielded against fine drifting sand. Its climbing ability was 25 percent.

The 1:4-scale model of the “Dernburg Wagen” reflects the most important details of the original, a superhuman achievement, particularly as the DaimlerChrysler model builders only had five measurements plus six contemporary photos to work from.

Other Mercedes-Benz passenger cars with all-wheel drive

In 1926 the know-how of the fledgling Daimler-Benz AG turned to building another high-traction passenger car, the three-axle G 1 (W 103 series). The G3 (1928) and G3a (1929) were subsequently developed based on this model. They were all driven at the two rear axles, making them ideal off-road vehicles despite their lack of true all-wheel drive capability. And the powerful G4 (W 31 series) also basically adopted the same design, although certain models also featured additional power transmission to the front axle. Heads of State and top military brass came to appreciate its virtues as a prestige all-terrain vehicle. In the 1930s,

Mercedes-Benz built other lightweight all-wheel drive vehicles, primarily for use in the German armed forces.

The Mercedes-Benz G5 (W 152 series, 1937 to 1941) was the precursor of today's privately owned off-roaders. Mercedes-Benz unveiled the G5 at the 1938 London Motor Show as a "colonial and hunting vehicle"; various bodies were available ex factory. In addition to all-wheel drive, it also had selectable all-wheel steering.

All-rounder with stature: the Unimog

In 1948, the Unimog was unveiled in Frankfurt/Main. The name was coined from the abbreviation of the German "Universalmotorgerät (Universal Motorized Unit)" – similarly echoing the wide-ranging applications mastered by the all-wheel drive vehicle. Initially Maschinenfabrik Boehringer in Göppingen manufactured the Unimog before Daimler-Benz took over the entire concept in 1950; series production started in the Gaggenau plant in 1951. Over the decades the Unimog has stood the test of time in agricultural applications, long-distance trekking, municipal operations and with the military. It is a match for virtually any type of terrain.

The undoubted success of the Unimog concept is reflected in many of the original vehicle's hallmark characteristics that still remain even today: four identically sized wheels, all-wheel drive with differential locks front and rear, portal axles that can cope with rough terrain, shafts front and rear and a small platform to transport cargo and implements. Numerous variants are available ex factory, allowing the vehicle to be customised to meet very specific applications. And there's even been a lifestyle-oriented fun version: the Fun-Mog.

In 1979, Mercedes-Benz launched the G-Class. The cross-country vehicle was developed as part of cooperation between Daimler-Benz AG and Steyr-Daimler-Puch in Graz, Austria, in the form of the Geländefahrzeuggesellschaft mbH joint venture. Daimler-Benz subsequently took over full control but with production remaining in Graz at Steyr-Daimler-Puch, the current Magna Steyr. There are four G-Class model series, with various body variants, including a long or short Station Wagon, Cabriolet, panel van and pick-up. In countries like Austria, Switzerland and also in the Eastern European bloc, the G-Class is also marketed under the Puch brand name.

The 460 series set the ball rolling in 1979, only to be replaced later by the more comfortable 463 series (launched 1989), and the simpler 461 series (from 1991) built in parallel. Meanwhile the 462 series is at times assembled in Thessaloniki, Greece from completely knocked-down components.

In the initial conceptual phase, the G-Class was designed as a commercial vehicle. That was soon to change however and the vehicle customised to withstand punishing off-road terrain. The performance figures are outstanding: climbing ability up to 80 percent, directional stability up to 54 percent on lateral slopes, 21 centimetres ground clearance, angle of approach/departure 36/27 degrees respectively mean the G-Class can negotiate the most difficult off-road terrain effortlessly. At the same time the chassis provides safe, comfortable on-road handling.

Early customers included the police and military in many countries. Special versions were produced too, such as a hunting vehicle for the Saudi Arabian royal family, the extra-long G-Class developed by Mercedes-AMG or the "Popemobile" for Pope John Paul II.

The G-Class has been available with petrol and diesel engines offering a range of outputs in all the model years, including high-power AMG variants. It has kept pace with the very latest technology developments but refused to compromise as

far as its off-road capabilities were concerned. Over the years, its civilian customer base has become increasingly important, and the G-Class is now available as a comfort-oriented version as an option. The 463 series represented a major leap forward in this respect. The G-Class is also available as a GUARD special-protection version. From 2001 onwards, the classic off-road vehicle made its mark in the major North American market, with much of the production now ending up in the U.S. And the G-Class has long since earned its spurs as the straight-lined, uncompromising evergreen off-roader in the car market.

High tech for passenger cars: Mercedes-Benz 4MATIC

In the mid-1980s the time was also ripe to fit Mercedes-Benz passenger cars with all-wheel drive. The all-new 4MATIC technology made its debut in the 124 series E-Class in 1987; it combined mechanical and electronic components using state-of-the-art technology. The permanent all-wheel drive enhanced the already excellent characteristics of Mercedes-Benz vehicles. From 1999 onwards, the 4ETS Electronic Traction System teamed up with 4MATIC to act as differential locks.

Mercedes-Benz extended its all-wheel drive line-up for passenger cars in the 2003 model year. 32 vehicles were available with 4MATIC in five model series. And in the line-up for the first time was the W 220 series S-Class with short and long wheelbase. In 2006, the W 221 successor model series was unveiled, the first S-Class to combine a diesel engine with all-wheel drive, the S 320 CDI. Even the C-Class was fitted with 4MATIC as part of the 2003 all-wheel drive initiative for six-cylinder models.

Sport Utility Vehicle from Mercedes-Benz: the M-Class

In 1997, Mercedes-Benz made a foray into a newly emerging market by launching the M-Class (W 163 series). The Sport Utility Vehicle (SUV) was generally fitted with 4MATIC all-wheel drive. The M-Class combines the comfort and handling safety of a passenger car with the ruggedness and off-road capabilities of a cross-

country vehicle. And the fact it also offered ample room and optimum adaptability went down well, turning the first M-Class into a runaway success.

In 2005, the W 164 series M-Class took on the strengths of its predecessor, sporting cutting-edge technology, new powerful engines, the standard-fit 7G-TRONIC 7-speed automatic transmission, the even more effective 4MATIC all-wheel drive, AIRMATIC air suspension and the PRE-SAFE[®] anticipatory occupant protection system. The design added an extra sporty touch, courtesy of the flat windscreen, striking front wings and the shoulderline rising toward the rear.

Lots of room on four driven wheels: the R-Class touring SUV

In March 2005, Mercedes-Benz unveiled the R-Class touring SUV. The R-Class took the acknowledged strengths of established vehicle categories, such as sporty Saloon, Estate, MPV and SUV, and fused them to create a new car with a character all of its own. All engine variants were fitted with the 4MATIC all-wheel drive as standard.

The Viano 4MATIC, which celebrated its world premiere at the IAA Motor Show in Frankfurt/Main in September 2005, gets you to your destination effortlessly and safely, however adverse the conditions. The Viano 4MATIC can safely transport up to eight persons, whether for day-to-day or recreational purposes, however bad the conditions on the road or the weather may prove. It comes in two wheelbase and three length variants as well as the Viano MARCO POLO camper van.

A high-performance off-roader: the GL-Class

The North American International Auto Show 2006 in Detroit hosted the world premiere of the GL-Class in January 2006, to be followed by the European debut in Geneva in February. The extremely robust, spacious lightweight construction gives the new GL-Class advantages in terms of ride comfort, dynamism and safety compared with its rivals. The standard specification includes 4MATIC permanent all-wheel drive, providing the GL-Class with superb dynamic handling whatever the conditions.

Mercedes-Benz S 320 CDI 4MATIC

Engine

No. of cylinders/arrangement		6/V, 4 valves per cylinder
Displacement	cc	2987
Bore x stroke	mm	83.0 x 92.0
Rated output	kW/hp	173/235 at 3600
Rated torque	Nm	540 at 1600-2400 rpm
Compression ratio	:1	17.7
Mixture formation		High-pressure injection, common-rail technology, turbocharger, EDC

Power transfer

Power train		Permanent all-wheel drive, 45 : 55 (f/r) power split
Transmission		7-speed automatic transmission
Ratios	Final drive	2.65
	1st gear	4.38
	2nd gear	2.86
	3rd gear	1.92
	4th gear	1.37
	5th gear	1.00
	6th gear	0.82
	7th gear	0.73
	Reverse	-3.42

Chassis

Front axle	Four-link suspension, anti-dive, AIRMATIC air suspension, gas-pressure shock absorbers, stabiliser
Rear axle	Multi-link independent suspension, anti-squat and anti-dive, AIRMATIC air suspension, gas-pressure shock absorbers, stabiliser
Braking system	Internally ventilated disc brakes all round, perforated at the front, drum-type parking brake at rear, ABS, Brake Assist, ESP®
Steering	Power-assisted speed-sensitive rack-and-pinion steering, steering damper
Wheels	8 J x 17 ET 43
Tyres	235/55 R 17

Dimensions and weights

		Short wheelbase	Long wheelbase
Wheelbase	mm	3035	3165
Track front/rear	mm	1604/1606	1604/1606
Overall length	mm	5076	5206
Overall width	mm	1871	1871
Overall height	mm	1473	1473
Turning circle	m	11.8	12.2
Boot capacity*	l	560	560
EC kerb weight**	kg	2025	2070
Payload capacity (on road, EC)	kg	600	585
Perm. GVW	kg	2625	2655
Tank capacity/incl. reserve	l	90/11	90/11

Performance and fuel consumption

Acceleration 0-100 km/h	s	7.8	7.8
Top speed	km/h	245	245
Fuel consumption***	l/100 km	8.7-8.9	8.7-8.9

*Acc. to VDA measuring method; **Incl. 75 kg for driver and baggage; ***Combined

Mercedes-Benz S 500 4MATIC

Page 50

Engine

No. of cylinders/arrangement		8/V, 4 valves per cylinder
Displacement	cc	5461
Bore x stroke	mm	98.0 x 90.5
Rated output	kW/hp	285/388 at 6000
Rated torque	Nm	530 at 2800-4800 rpm
Compression ratio	:1	10.7
Mixture formation		Microprocessor-controlled petrol injection with hot film mass airflow sensor

Power transfer

Power train		Permanent all-wheel drive, 45 : 55 (f/r) power split	
Transmission		7-speed automatic transmission	
Ratios	Final drive	2.65	
	1st gear	4.38	
	2nd gear	2.86	
	3rd gear	1.92	
	4th gear	1.37	
	5th gear	1.00	
	6th gear	0.82	
	7th gear	0.73	
	Reverse	-3.42	

Chassis

Front axle		Four-link suspension, anti-dive, AIRMATIC air suspension, gas-pressure shock absorbers, stabiliser
Rear axle		Multi-link independent suspension, anti-squat and anti-dive, AIRMATIC air suspension, gas-pressure shock absorbers, stabiliser
Braking system		Internally ventilated disc brakes all round, perforated at the front, drum-type parking brake at rear, ABS, Brake Assist, ESP [®]
Steering		Power-assisted speed-sensitive rack-and-pinion steering, steering damper
Wheels		8 J x 17 ET 43
Tyres		235/55 R 17

Dimensions and weights

		Short wheelbase	Long wheelbase
Wheelbase	mm	3035	3165
Track front/rear	mm	1604/1606	1604/1606
Overall length	mm	5076	5206
Overall width	mm	1871	1871
Overall height	mm	1473	1473
Turning circle	m	11.8	12.2
Boot capacity*	l	560	560
EC kerb weight**	kg	2010	2055
Payload capacity (on road, EC)	kg	610	585
Perm. GVW	kg	2620	2640
Tank capacity/incl. reserve	l	90/11	90/11

Performance and fuel consumption

Acceleration 0-100 km/h	s	5.4	5.4
Top speed	km/h	250	250
Fuel consumption***	l/100 km	12.1-12.3	12.2-12.4

*Acc. to VDA measuring method; **Incl. 75 kg for driver and baggage; ***Combined

Mercedes-Benz E 320 CDI 4MATIC

Page 52

Engine

No. of cylinders/arrangement		6/V, 4 valves per cylinder
Displacement	cc	2987
Bore x stroke	mm	83.0 x 92.0
Rated output	kW/hp	165/224 at 3800 rpm
Rated torque	Nm	510 at 1600-2800 rpm
Compression ratio	:1	17.7
Mixture formation		High-pressure injection with common-rail technology, turbocharger, EDC

Power transfer

Power train		Permanent all-wheel drive, 40 : 60 (f/r) power split
Transmission		5-speed automatic transmission
Ratios	Final drive	2.47
	1st gear	3.95
	2nd gear	2.42
	3rd gear	1.49
	4th gear	1.00
	5th gear	0.83
	Reverse	-3.15

Chassis

Front axle		Double wishbone, anti-dive, coil springs, gas-pressure shock absorbers, stabiliser
Rear axle		Multi-link independent suspension, anti-squat and anti-dive, coil springs, gas-pressure shock absorbers, stabiliser
Braking system		Internally ventilated disc brakes all round, drum-type parking brake at rear, ABS, Brake Assist, ESP [®]
Steering		Power-assisted speed-sensitive rack-and-pinion steering, steering damper
Wheels		7.5 J x 16
Tyres		225/55 R 16

Dimensions and weights

Wheelbase	mm	2854
Track front/rear	mm	1557/1552
Overall length	mm	4856
Overall width	mm	1822
Overall height	mm	1499
Turning circle	m	11.5
Boot capacity max.*	l	540
EC kerb weight**	kg	1845
Payload capacity (on road, EC)kg		525
Perm. GVW	kg	2370
Tank capacity/incl. reserve	l	80/9

Performance and fuel consumption

Acceleration 0-100 km/h	s	7.4
Top speed	km/h	244
Fuel consumption***.	l/100 km	7.9-8.1

*Acc. to VDA measuring method; **Incl. 75 kg for driver and baggage; ***Combined

Mercedes-Benz E 500 4MATIC

Page 53

Engine

No. of cylinders/arrangement		8/V, 4 valves per cylinder
Displacement	cc	5461
Bore x stroke	mm	98.0 x 90.5
Rated output	kW/hp	285/388 at 6000 rpm
Rated torque	Nm	530 at 2800-4800 rpm
Compression ratio	:1	10.7
Mixture formation		Microprocessor-controlled petrol injection with hot film mass airflow sensor

Power transfer

Power train		Permanent all-wheel drive, 40 : 60 (f/r) power split
Transmission		5-speed automatic transmission
Ratios	Final drive	3.07
	1st gear	3.60
	2nd gear	2.19
	3rd gear	1.41
	4th gear	1.00
	5th gear	0.83
	Reverse	-3.17

Chassis

Front axle		Double wishbone, AIRMATIC DC all-round self-levelling suspension, anti-dive
Rear axle		Multi-link independent suspension, AIRMATIC DC all-round self-levelling suspension, anti-squat and anti-dive
Braking system		Internally ventilated disc brakes all round, drum-type parking brake at rear, ABS, Brake Assist, ESP®
Steering		Power-assisted speed-sensitive rack-and-pinion steering, steering damper
Wheels		8 J x 17
Tyres		245/45 R 17

Dimensions and weights

Wheelbase	mm	2854
Track front/rear	mm	1565/1560
Overall length	mm	4856
Overall width	mm	1822
Overall height	mm	1475
Turning circle	m	11.5
Boot capacity max.*	l	530
EC kerb weight**	kg	1880
Payload capacity (on road, EC) kg		525
Perm. GVW	kg	2405
Tank capacity/incl. reserve	l	80/9

Performance and fuel consumption

Acceleration 0-100 km/h	s	5.5
Top speed	km/h	250
Fuel consumption***	l/100 km	12.3

* Acc. to VDA measuring method; **Incl. 75 kg for driver and baggage; ***Combined

Mercedes-Benz ML 320 CDI 4MATIC

Page 54

Engine		
No. of cylinders/arrangement		6/V, 4 valves per cylinder
Displacement	cc	2987
Bore x stroke	mm	83 x 92
Rated output	kW/hp	165/224
Rated torque	Nm	510 at 1600-2800 rpm
Compression ratio	:1	17.7
Mixture formation		Common-rail direct injection, turbocharger, EDC
Power transfer		
Power train		Permanent all-wheel drive, 4MATIC, ESP [®] , 4ETS; 50 : 50 (f/r) power split
Transmission		7-speed automatic transmission
Gear ratio reduction	i =	2.93
Final drive	i =	3.45
Ratios	1st gear	4.38
	2nd gear	2.86
	3rd gear	1.92
	4th gear	1.37
	5th gear	1.0
	6th gear	0.82
	7th gear	0.73
	Reverse	-3.42
Chassis		
Front axle		Double wishbone suspension, coil springs, gas-pressure shock absorbers, anti-dive, stabiliser
Rear axle		Four-link suspension, coil springs, gas-pressure shock absorbers, anti-squat and anti-dive, stabiliser
Braking system		Disc brakes all round, internally ventilated at the front, drum-type parking brake at rear, ABS, Brake Assist
Steering		Power-assisted speed-sensitive rack-and-pinion steering, steering damper
Wheels		7.5 J x 17
Tyres		235/65 R 17
Dimensions and weights		
Wheelbase	mm	2915
Track front/rear	mm	1627/1629
Overall length	mm	4780
Overall width	mm	1911
Overall height	mm	1815
Turning circle	m	11.6
Boot capacity*	l	551-2050
EC kerb weight**	kg	2185
Payload capacity (on road, EC) kg		720
Perm. GVW	kg	2830
Towing capacity (braked)	kg	3500
Unbraked	kg	750
Tank capacity/incl. reserve	l	95/13
Performance and fuel consumption		
Acceleration 0-100 km/h	s	8.6
Top speed	km/h	215
Fuel consumption***	l/100 km	9.4-9.6

*Acc. to VDA measuring method; **Incl. 75 kg for driver and baggage; ***Combined

Mercedes-Benz GL 320 CDI 4MATIC

Page 55

<u>Engine</u>		
No. of cylinders/arrangement		V/6, 4 valves per cylinder
Displacement	cc	2987
Bore x stroke	mm	83.0 x 92.0
Rated output	kW/hp	165/224 at 3800 rpm
Rated torque	Nm	510 at 1600-2800 rpm
Compression ratio	:1	17.7
Mixture formation		Common-rail direct injection, turbocharger, EDC
<u>Power transfer</u>		
Power train		4MATIC permanent all-wheel drive, ESP [®] , 4ETS; two-step transfer case with multi-disc limited-slip differential (up to 100%) and multi-disc limited-slip differential on the rear axle (up to 100%), 50 : 50 (f/r) power split
Transmission		7-speed automatic transmission
Gear ratio reduction	i =	2.93
Final drive	i =	3.45
Gear spacing, i =	1st gear	4.38
	2nd gear	2.86
	3rd gear	1.92
	4th gear	1.37
	5th gear	1.00
	6th gear	0.82
	7th gear	0.73
	Reverse	-3.42
<u>Chassis</u>		
Front axle		Double wishbone suspension, AIRMATIC DC all-round self-levelling suspension, anti-dive, stabiliser
Rear axle		Four-link suspension, AIRMATIC DC self-levelling suspension, anti-dive, stabiliser, anti-squat and anti-dive
Braking system		Internally ventilated disc brakes all round, drum-type parking brake at rear, ABS, Brake Assist
Steering		Power-assisted speed-sensitive rack-and-pinion steering, steering damper
Wheels		8 J x 18
Tyres		265/60 R 18
<u>Dimensions and weights</u>		
Wheelbase	mm	3075
Track front/rear	mm	1651/1654
Overall length	mm	5088
Overall width	mm	1920
Overall height	mm	1840
Turning circle	m	12.1
Boot capacity*	l	300-2300
EC kerb weight**	kg	2450 (2550)
Payload capacity (on road, EC)	kg	700
Perm. GVW	kg	3150 (3250)
Towing capacity (braked)	kg	3500
Unbraked	kg	750
Tank capacity/incl. reserve	l	100/13

Performance and fuel consumption

Acceleration 0-100 km/h	s	9.5
Top speed	km/h	210
Fuel consumption***	l/100 km	9.8-10.0

Page 56

Figures in brackets refer to seven-seater version; * Acc. to VDA measuring method; ** Incl. 75 kg for driver and baggage; *** Combined

Mercedes-Benz GL 450 4MATIC

Page 57

Engine

No. of cylinders/arrangement		V/8, 4 valves per cylinder
Displacement	cc	4663
Bore x stroke	mm	92.9 x 86
Rated output	kW/hp	250/340 at 6000 rpm
Rated torque	Nm	460 at 2700-5000 rpm
Compression ratio	:1	10.7
Mixture formation		Microprocessor-controlled fuel injection, HFM

Power transfer

Power train		4MATIC permanent all-wheel drive, ESP [®] , 4ETS; two-step transfer case with multi-disc limited-slip differential (up to 100%) and multi-disc limited-slip differential on the rear axle (up to 100%), 50 : 50 (f/r) power split
Transmission		7-speed automatic transmission
Gear ratio reduction	i =	2.93
Final drive	i =	3.70
Gear spacing, i =	1st gear	4.38
	2nd gear	2.86
	3rd gear	1.92
	4th gear	1.37
	5th gear	1.00
	6th gear	0.82
	7th gear	0.73
Reverse		-3.42

Chassis

Front axle		Double wishbone suspension, AIRMATIC DC all-round self-levelling suspension, anti-dive, stabiliser
Rear axle		Four-link suspension, AIRMATIC DC self-levelling suspension, anti-dive, stabiliser, anti-squat and anti-dive
Braking system		Internally ventilated disc brakes all round, drum-type parking brake at rear, ABS, Brake Assist
Steering		Power-assisted speed-sensitive rack-and-pinion steering, steering damper
Wheels		8.5 J x 19
Tyres		275/55 R 19

Dimensions and weights

Wheelbase	mm	3075
Track front/rear	mm	1645/1648
Overall length	mm	5088
Overall width	mm	1920
Overall height	mm	1840
Turning circle	m	12.1
Boot capacity*	mm	300-2300
EC kerb weight**	mm	2430 (2530)
Payload capacity (on road, EC)	mm	720
Perm. GVW	kg	3150 (3250)
Towing capacity (braked)	kg	3500
Unbraked	kg	750
Tank capacity/incl. reserve	l	100/13

Performance and fuel consumption

Acceleration 0-100 km/h	s	7.2
Top speed	km/h	235
Fuel consumption***	l/100 km	13.3-13.5

Page 58

Figures in brackets refer to seven-seater version; * Acc. to VDA measuring method; ** Incl. 75 kg for driver and baggage; *** Combined

Mercedes-Benz R 350 4MATIC

Engine

No. of cylinders/arrangement		6/V, 4 valves per cylinder
Displacement	cc	3498
Bore x stroke	mm	92.9 x 86.0
Rated output	kW/hp	200/272 at 6000 rpm
Rated torque	Nm	350 at 2400-500 rpm
Compression ratio	:1	10.7
Mixture formation		Microprocessor-controlled fuel injection, HFM

Power transfer

Power train		Permanent all-wheel drive, 4MATIC, ESP [®] , 4ETS; 50 : 50 (f/r) power split
Transmission		7-speed automatic transmission
Final drive	i =	3.70
Ratios	1st gear	4.38
	2nd gear	2.86
	3rd gear	1.92
	4th gear	1.37
	5th gear	1.0
	6th gear	0.82
	7th gear	0.73
	Reverse	-3.42

Chassis

Front axle		Double wishbone suspension, coil springs, gas-pressure shock absorbers, anti-dive, stabiliser
Rear axle		Four-link suspension, air suspension system, anti-squat and anti-dive, stabiliser
Braking system		Disc brakes all round, internally ventilated at the front, drum-type parking brake at rear, ABS, Brake Assist
Steering		Power-assisted speed-sensitive rack-and-pinion steering, steering damper
Wheels		7.5 J x 17
Tyres		235/65 R 17

Dimensions and weights

Wheelbase	mm	2980 (3215)
Track front/rear	mm	1665/1658
Overall length	mm	4922 (5157)
Overall width	mm	1922
Overall height	mm	1659 (1656)
Turning circle	m	11.7 (12.4)
Boot capacity*	l	244-1950 (314-2385)
EC kerb weight**	kg	2155 (2205)
Payload capacity (on road, EC) kg		655 (625)
Perm. GVW	kg	2810 (2860)
Towing capacity (braked)	kg	2100
Unbraked	kg	750
Tank capacity/incl. reserve	l	80/13

Performance and fuel consumption

Acceleration 0-100 km/h	s	8.3 (8.4)
Top speed	km/h	230
Fuel consumption***	l/100 km	11.4-11.6 (11.5-11.7)

Figures in brackets refer to long wheelbase; *Acc. to VDA measuring method; **Incl. 75 kg for driver and baggage; ***Combined

Mercedes-Benz R 500 4MATIC

Page 60

<u>Engine</u>		
No. of cylinders/arrangement		8/V, 3 valves per cylinder
Displacement	cc	4966
Bore x stroke	mm	97 x 84
Rated output	kW/hp	225/306
Rated torque	Nm	460 at 2700-4750 rpm
Compression ratio	:1	10.0
Mixture formation		Microprocessor-controlled fuel injection, HFM
<u>Power transfer</u>		
Power train		Permanent all-wheel drive, 4MATIC, ESP [®] , 4ETS; 50 : 50 (f/r) power split
Transmission		7-speed automatic transmission
Final drive	i =	3.45
Ratios	1st gear	4.38
	2nd gear	2.86
	3rd gear	1.92
	4th gear	1.37
	5th gear	1.0
	6th gear	0.82
	7th gear	0.73
	Reverse	-3.42
<u>Chassis</u>		
Front axle		Double wishbone suspension, coil springs, gas-pressure shock absorbers, anti-dive, stabiliser
Rear axle		Four-link suspension, air suspension system, anti-squat and anti-dive, stabiliser
Braking system		Internally ventilated disc brakes all round, drum-type parking brake at rear, ABS, Brake Assist
Steering		Power-assisted speed-sensitive rack-and-pinion steering, steering damper
Wheels		8 x 18
Tyres		255/55 R 18
<u>Dimensions and weights</u>		
Wheelbase	mm	2980 (3215)
Track front/rear	mm	1643/1636
Overall length	mm	4922 (5157)
Overall width	mm	1922
Overall height	mm	1659 (1656)
Turning circle	m	11.7 (12.4)
Boot capacity*	l	244-1950 (314-2385)
EC kerb weight**	kg	2190 (2240)
Payload capacity (on road, EC) kg		675 (655)
Perm. GVW	kg	2865 (2895)
Towing capacity (braked)	kg	2100
Unbraked	kg	750
Tank capacity/incl. reserve	l	80/13
<u>Performance and fuel consumption</u>		
Acceleration 0-100 km/h	s	6.9 (7.0)
Top speed	km/h	245
Fuel consumption***	l/100 km	13.3-13.9 (13.3-13.9)

Figures in brackets refer to long wheelbase; *Acc. to VDA measuring method; **Incl. 75 kg for driver and baggage; ***Combined

Mercedes-Benz G 320 CDI

Page 61

Engine		
No. of cylinders/arrangement		V/6, 4 valves per cylinder
Displacement	cc	2987
Bore x stroke	mm	83.0 x 92.0
Rated output	kW/hp	165/224 at 3800 rpm
Rated torque	Nm	510 at 1600-2400 rpm
Compression ratio	:1	17.7
Mixture formation		Common-rail direct injection, turbocharger, EDC
Power transfer		
Power train		Permanent all-wheel drive, ESP [®] , 4ETS; two-step transfer case with three 100-percent differential locks 50 : 50 (f/r) power split
Transmission		7-speed automatic transmission
Gear ratio reduction	i =	2.93
Final drive	i =	4.38
Gear spacing,	1st gear	4.38
	2nd gear	2.86
	3rd gear	1.92
	4th gear	1.37
	5th gear	1.00
	6th gear	0.82
	7th gear	0.73
Reverse		-3.42
Chassis		
Front axle		Rigid axle with trailing arms and transverse links, gas-pressure shock absorbers, coil springs, hollow rubber springs, torsion bar stabiliser
Rear axle		Rigid axle with trailing arms and transverse links, gas-pressure shock absorbers, coil springs, hollow rubber springs
Braking system		Hydraulic dual-circuit braking system with brake booster, stepped master brake cylinder, ABS, solid disc brakes all round, lever-type handbrake
Steering		Recirculating ball, power-assisted with steering damper
Wheels		7.5 J x 16
Tyres		265/70 R 16
Dimensions and weights		
Wheelbase	mm	2850
Track front/rear	mm	1475/1475
Overall length	mm	4662
Overall width	mm	1760
Overall height	mm	1931
Turning circle	m	13.3
Boot capacity	l	480-2250
EC kerb weight**	kg	2445
Payload capacity (on road, EC)	kg	755
Perm. GVW	kg	3200
Towing capacity (braked)	kg	3500
Unbraked	kg	750
Tank capacity/incl. reserve	l	96/20

Performance and fuel consumption

Acceleration 0-100 km/h	s	9.1
Top speed	km/h	177
Fuel consumption***	l/100 km	11.0

Page 62

*Acc. to VDA measuring method; **Incl. 75 kg for driver and baggage; ***Combined